

TOP VIEW

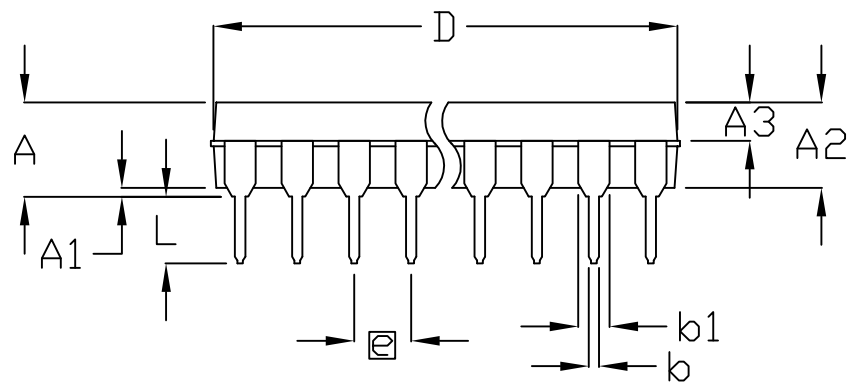

SIDE VIEW

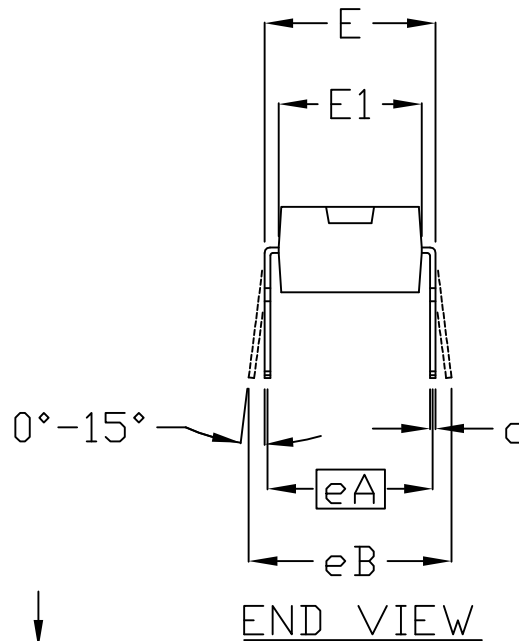

END VIEW

	INCHES		MILLIMETERS	
	MIN	MAX	MIN	MAX
A	---	0.180	---	4.572
A1	0.015	---	0.38	---
A2	0.125	0.175	3.18	4.45
A3	0.055	0.080	1.40	2.03
B	0.015	0.022	0.381	0.56
B1	0.045	0.065	1.14	1.65
C	0.008	0.014	0.2	0.355
D1	0.005	0.080	0.13	2.03
E	0.300	0.325	7.62	8.26
E1	0.240	0.310	6.10	7.87
e	0.100 BSC.		2.54 BSC.	
eA	0.300 BSC.		7.62 BSC.	
eB	0.400 BSC.		10.16 BSC.	
L	0.115	0.150	2.921	3.81

VARIATIONS:

	INCHES		MILLIMETERS		N	MS001	PKG CODE
	MIN	MAX	MIN	MAX			
D	0.348	0.390	8.84	9.91	8	AB	P8-1, P8-3, P8-4, P8-5
D	0.735	0.765	18.67	19.43	14	AC	P14-3, P14-4, P14-6, P14-7 P14M-4, P14M-5, P14M-7
D	0.745	0.765	18.92	19.43	16	AA	P16-1, P16-2, P16-3, P164, P16-7F, P16-8, P16-9
D	0.885	0.915	22.48	23.24	18	AD	P18-2, P18-5, P18-6, P18-7, P18-9
D	1.015	1.045	25.78	26.54	20	AE	P20-2, P20-3, P20-4, P20M-1
D	1.14	1.265	28.96	32.13	24	AF	N24-1, N24-3, N24-4, N24-5, N24-8, N24-9F; N24M-1
D	1.360	1.380	34.54	35.05	28	*5	N28-1F, N28-2, N28-4, N28M-1

NOTES:

1. DIMENSIONS ARE IN MILLIMETERS UNLESS OTHERWISE SPECIFIED.
2. D&E DO NOT INCLUDE MOLD FLASH.
3. MOLD FLASH OR PROTRUSIONS NOT TO EXCEED 0.15mm (.006").
4. MMEETS JEDEC MS001-XX AS SHOWN IN ABOVE TABLE
5. SIMILIAR TO JEDEC MO-058AB
6. N = NUMBER OF PINS
7. MATERIAL MUST COMPLY WITH BANNED AND RESTRICTED SUBSTANCES SPEC # 10-0131.
8. ALL DIMENSIONS APPLY TO BOTH LEADED (-) AND PbFREE (+) PKG. CODES.

-DRAWING NOT TO SCALE-



TITLE:
PACKAGE OUTLINE,
PDIP .300"

APPROVAL
Scott Schroeder
04-20-11

DOCUMENT CONTROL NO.
21-0043

REV. 1/1
E