



[Maxim](#) > [Design Support](#) > [Technical Documents](#) > [Reference Schematics](#) > [1-Wire® Devices](#) > [APP 244](#)

[Maxim](#) > [Design Support](#) > [Technical Documents](#) > [Reference Schematics](#) > [iButton®](#) > [APP 244](#)

[Maxim](#) > [Design Support](#) > [Technical Documents](#) > [Reference Schematics](#) > [Microcontrollers](#) > [APP 244](#)

Keywords: 1-Wire master, microcontroller, network driver

## REFERENCE SCHEMATIC 244

# Advanced 1-Wire Network Driver

By: Bernhard Linke, Principal Member Technical Staff

May 30, 2003

*Abstract: This document describes a microcontroller-based 1-Wire® master interface for reliable operation of small, medium, and large 1-Wire networks. This is accomplished using careful impedance matching, intelligent (software-controlled) active pullup, and slew-rate control. Software flow charts are included to assist the user in generating the correct 1-Wire timing for reset pulse, presence detect, write one, write zero, and read time slots using any suitable microcontroller. Scope traces illustrate the timing performance of the driver as well as transmission line effects as they appear with long cables.*

## Introduction

To a large degree, the reliability of a 1-Wire network depends on the characteristics of the driver circuit that the host computer uses to communicate with 1-Wire slave devices. This document describes a 1-Wire master interface that uses careful impedance matching and an "intelligent" (software-controlled) strong pullup to accomplish reliable operation in networks from very lightweight to very heavy, up to 500m equivalent size. For guidelines on how to create reliable 1-Wire networks see tutorial 148, "[Guidelines for Reliable Long Line 1-Wire Networks](#)".

## Circuit Description

The network driver (**Figure 1**) consists of a pulldown section (Q1, R1, C1, R5) and a pullup section (Q2, R2, C2, R6). A third transistor and surrounding components (Q3, C4, R7) form a strong pullup section to supply extra power for devices such as EEPROMs, or temperature sensors. This "strong-pullup" function is not discussed in this document. Of the three transistors, a maximum of one is conducting at any time. When there is no 1-Wire communication ("idle" state), all three transistors are nonconducting.

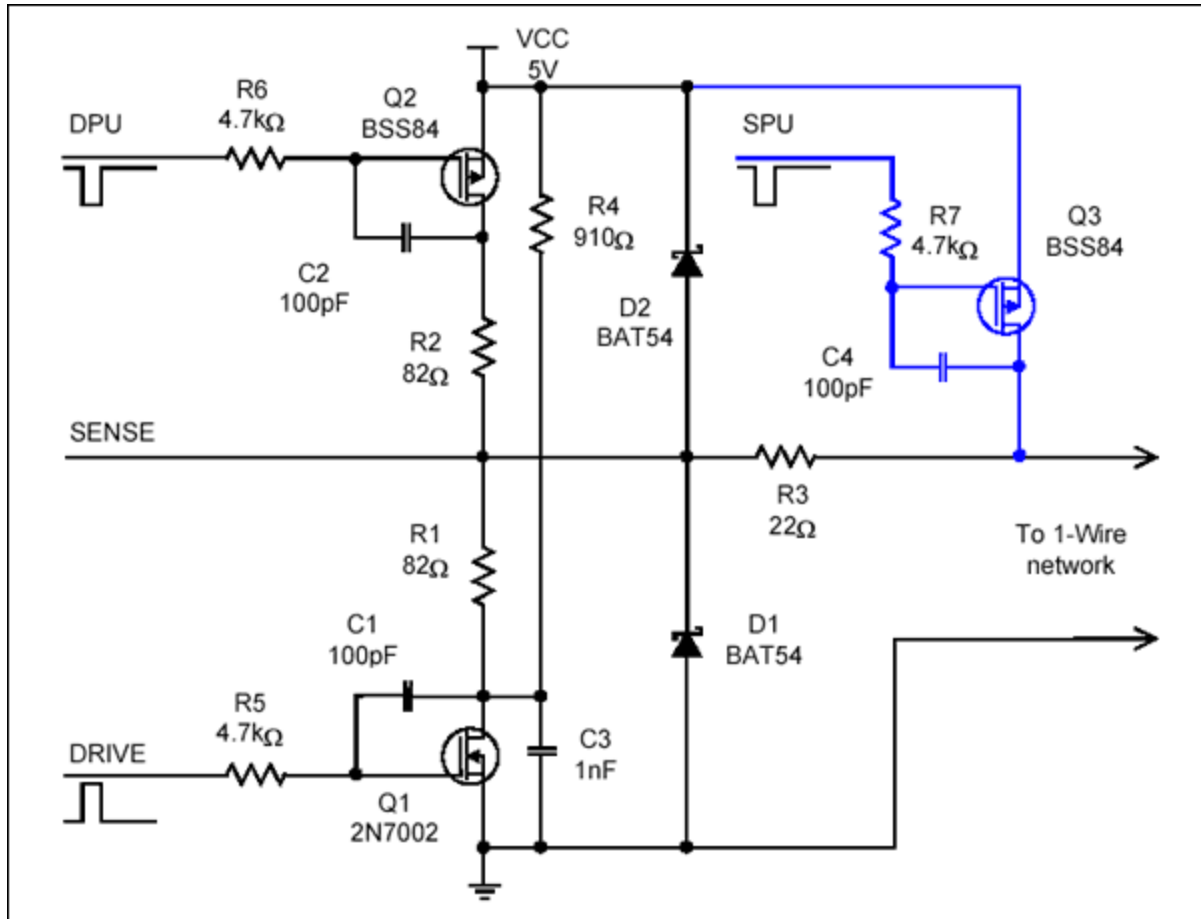

Figure 1. Driver schematic.

The series path of R4, R1, and R3 provides the standard 1-Wire pullup to  $V_{CC}$ . With this circuit, the total pullup resistance is approximately 1kΩ. This value applies when the 1-Wire line is idle. Since R4 is connected to the drain of Q1, the current flowing through it when Q1 is conducting does not affect the lowlevel voltage on the 1-Wire line. R4 + R1 + R3 together with the load or "weight" of the 1-Wire network determine the speed at which the voltage on the 1-Wire rises to 5V. Lowering R4 is not recommended since it raises the low-level voltage on the 1-Wire, which is undesirable. The Schottky diodes D1 and D2 eliminate spikes from electrostatic discharge (ESD) hits or cross coupling from other cabling nearby by conducting them to GND and  $V_{CC}$ , respectively. R3 limits the ESD current and protects D1 and D2.

A special characteristic of this driver is the proper line termination of the 1-Wire cable on the master end. The category 5 unshielded twisted-pair data cable, which is recommended for 1-Wire applications, has a characteristic impedance of approximately 100Ω. Line termination is accomplished through R1 or R2 in series with R3 when Q1 or Q2 is conducting. C3 in series with R1 and R3 provide an AC-coupled termination for presence pulses. To adapt this driver to a different impedance, R1 and R2 need to be changed accordingly.

All three sections of this driver are slew-rate controlled when the associated transistor is turned on. R5 and C1 limit the slew rate when the driver pulls the 1-Wire line low, e.g., at the beginning of a time slot or a reset pulse. R6 and C2 limit the slew rate when the dynamic pullup becomes active. R7 and C4

limit the slew rate of the active pullup. The time constant of all three sections is  $0.5\mu\text{s}$ . This value results in a slew rate of approximately  $4\text{V}/\mu\text{s}$ . For details and scope traces see the *Performance Examples* section.

## Circuit Operation

Disregarding the strong pullup circuitry (Q3, R7, C4) the driver requires three connections to a supervising microcontroller. These signals are called DRIVE, DPU, and SENSE. DRIVE is an active-high signal that initiates 1-Wire communication by turning on Q1. DPU is an active-low signal that activates the dynamic pullup Q2. SENSE is essentially a through-connection from the 1-Wire line to an input port of the microcontroller. 1-Wire ground and driver/microcontroller GND are the same. To perform 1-Wire communication it is necessary to properly generate the DRIVE and DPU signals and to read from the 1-Wire line through the SENSE input at the appropriate times. 1-Wire communication knows four cases of waveforms; these are reset/presence-detect sequence, and the three cases of communication time slots.

### Reset Presence and Detect

All 1-Wire communication begins with a reset pulse followed by a window for the presence pulse. Figure 2 shows the 1-Wire waveform. To generate the reset pulse, the DRIVE signal is activated for a duration from A to B (see **Figure 2**). Starting at A, the voltage on the 1-Wire ramps down to 0V. As DRIVE gets inactive at B, the voltage on the 1-Wire starts rising, unless a 1-Wire device pulls the line low to signal an interrupt condition (see [DS1904](#) and [DS2417](#) data sheets, Type 2 Interrupt). To properly accommodate this interrupt case, the status of the 1-Wire is sampled repeatedly starting at C until the 1-Wire has reached a logic high level at D. Shortly after D, the dynamic pullup DPU is activated (point E). This quickly pulls the 1-Wire line to 5V. At F the dynamic pullup ends. Assuming that a 1-Wire device is present, it generates a presence pulse, which begins at G and ends at I. At H, somewhere between G and I, the status on the 1-Wire is sampled to test whether a 1-Wire device is present. As the presence pulse ends, the voltage on the 1-Wire starts rising towards 5V. At J the logic status of the 1-Wire is sampled again to detect whether a Type 1A interrupt (see [DS1904/DS2417](#) data sheets) is signaled. Without interrupt, the logic state is high, as shown in Figure 2, and the dynamic pullup is activated again from K to L, which ensures that the 1-Wire line is fully recharged. With interrupt signal, the status sensed at J is a logic zero and another series of repeated sampling, exactly like that at the end of the reset pulse is necessary (i.e., going back to C and continue sampling). The interrupt pulse is understood as a reset pulse by other 1-Wire devices. Therefore they generate a presence pulse as the response, except for the interrupting device (i. e., when J is reached in the second pass, the logic status of the 1-Wire is high, as shown in Figure 2. In any case, the reset/presence-detect sequence ends at M, where a time slot begins.

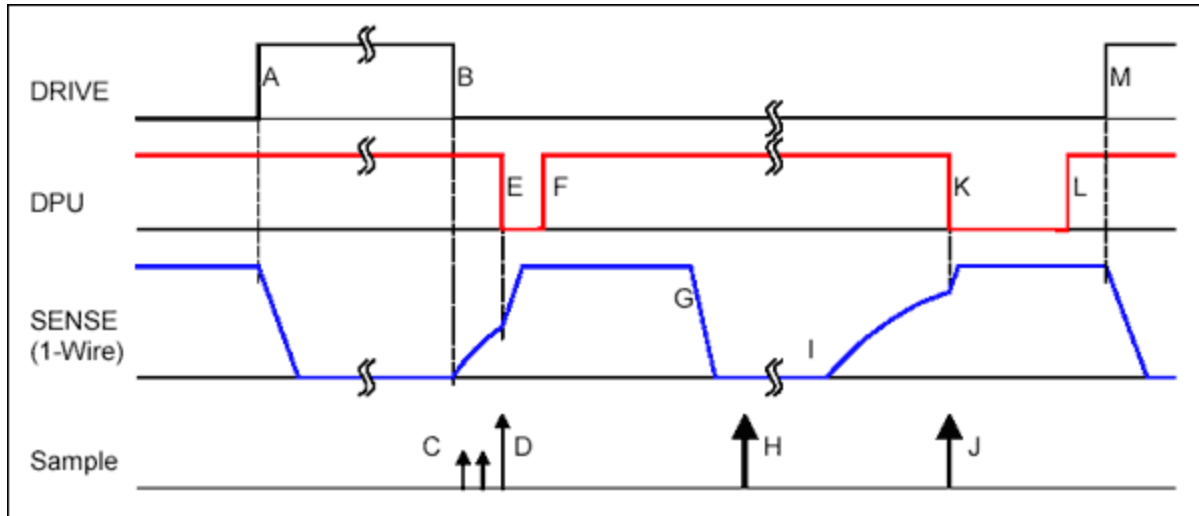

Figure 2. Reset and presence-detect sequence.

A to B	B to C	D to E	E to F	E to H	H to J	J to K	K to L	L to M
480µs	0 to 2µs	0 to 2µs	8µs	72µs	240µs	0 to 2µs	60µs	> 2µs

The sampling point H must be chosen to hit the presence pulse window, which is determined by the timing spread between the fastest and the slowest 1-Wire device present. Data sheets specify this window as  $t_{MSP}$ . The timing reference for  $t_{MSP}$  begins when the 1-Wire device detects logic-HIGH level after the reset pulse is over. In Figure 2 this reference point approximately coincides with E. The duration from A to C is equivalent to the sum of  $t_F$  (fall time) and  $t_{RSTL}$  (reset low time). In case of a Type 2 interrupt, the effective reset low time is the sum of A to B and the duration of the interrupt pulse (see DS1904 and DS2417 data sheets). The time from E to M is called reset high time  $t_{RSTH}$ . Data sheets specify  $t_{RSTL}$  and indicate how to determine the minimum duration of  $t_{RSTH}$ . There is no maximum for  $t_{RSTH}$ .

## Communication Time Slots

### Write Zero Time Slot

The write zero time slot transmits a 0-bit on the 1-Wire line. **Figure 3** shows the 1-Wire waveform. To generate the write zero time slot, the DRIVE signal is activated for a duration from A to B0. Starting at A, the voltage on the 1-Wire ramps down to 0V. As DRIVE becomes inactive at B0, the voltage on the 1-Wire line starts rising. Shortly after B0, the dynamic pullup DPU is activated (point C0). This quickly pulls the 1-Wire line to 5V. At D0 the dynamic pullup ends. The next time slot or a reset/presence-detect sequence may follow at E0.

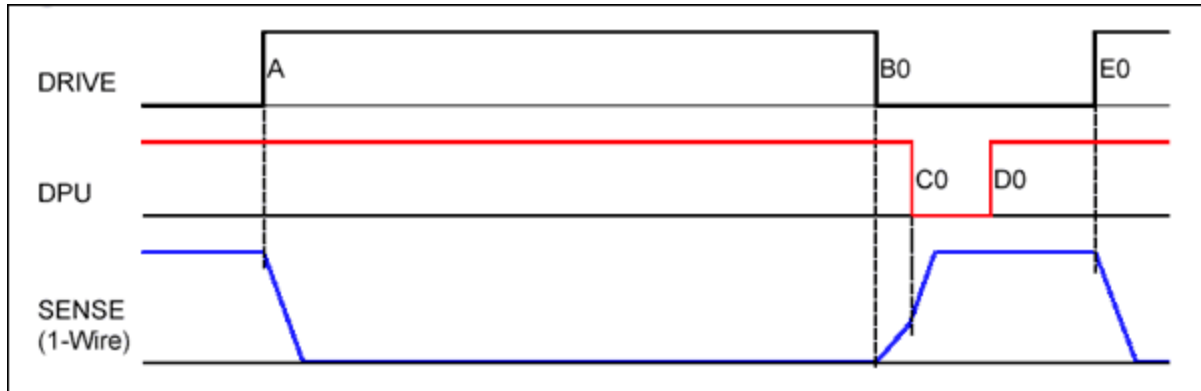

Figure 3. Write zero time slot.

A write zero time slot does not require sampling the data line. Therefore Figure 3 does not show any sampling point. However, it is definitely permissible to sample the 1-Wire line at the same point in time as with a read time slot (Figure 4 or 5). The sampled logic state is always 0, indicating that the circuit actually writes a 0 to the 1-Wire line. The duration from A to C0 is equivalent to the sum of  $t_F$  (fall time) and  $t_{W0L}$  (write zero low time). The time from C0 to E0 is called recovery time  $t_{REC}$ . Data sheets specify  $t_{W0L}$  and a minimum value for  $t_{REC}$ . The time from A to E0 is also referred to as time slot duration  $t_{SLOT}$ .

Table 2. Recommended Timing Values for Write Zero Time Slot			
A to B0	B0 to C0	C0 to D0	A to E0
60 $\mu$ s	2 $\mu$ s	16 $\mu$ s	80 $\mu$ s

### Write One/Read Time Slot (Read One)

The write one time slot transmits a 1-bit on the 1-Wire line. **Figure 4** shows the 1-Wire waveform. Reading a 1-bit from the 1-Wire line results in exactly the same waveform as writing a 1-bit. Therefore, the write one and read one case are combined and discussed as a single case. To generate the write one or read time slot, the DRIVE signal is activated for a duration from A to BR. Starting at A, the voltage on the 1-Wire ramps down to 0V. As DRIVE becomes inactive at BR, in the case of reading or writing a 1-bit, the voltage on the 1-Wire line starts rising. At CR the status on the 1-Wire is sampled. Since the bit read is a 1, the dynamic pullup is activated immediately, lasting from D1 to E1. This quickly pulls the 1-Wire line to 5V. The next time slot or a reset/presence-detect sequence may begin at F1.

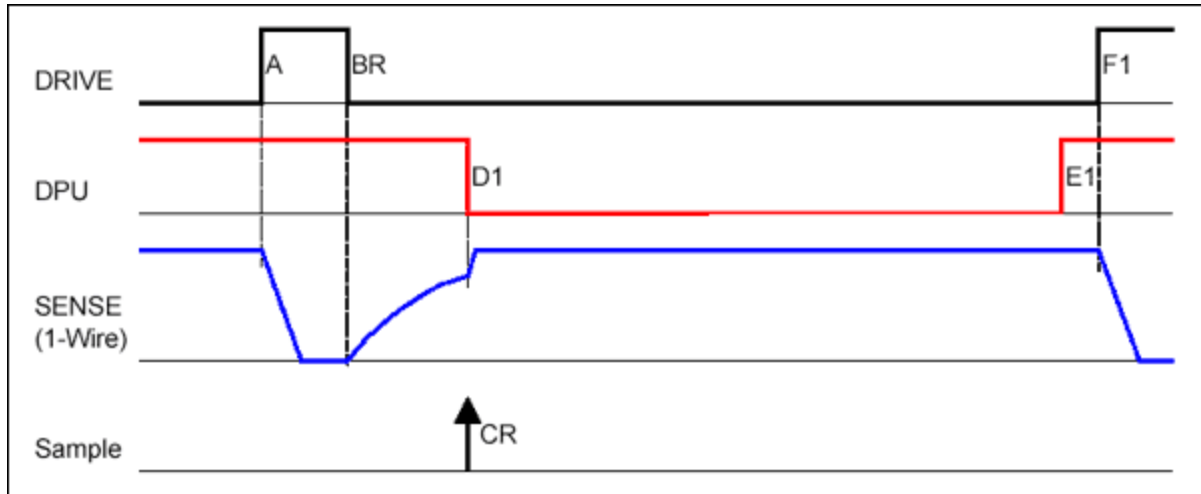

Figure 4. Write one/read time slot (read one).

The sampling point CR must be chosen to hit the master sampling window, which is determined by the timing of the fastest 1-Wire device. In data sheets this window is called  $t_{MSR}$ . The timing reference for  $t_{MSR}$  begins when the 1-Wire device detects a logic LOW-level after the beginning of the time slot. In Figure 4 this reference point is approximately A plus fall time  $t_F$ . The duration from A to BR is equivalent to the sum of  $t_F$  (fall time) and  $t_{RL}$  (read low time). Data sheets specify  $t_{RL}$  (equal to  $t_{W1L}$ ) and  $t_{MSR}$ . The time from A to F1 is also referred to as time slot duration  $t_{SLOT}$ .

Table 3. Recommended Timing Values for Write One/Read Time Slot (Read One)				
A to BR	A to CR	CR to D1	D1 to E1	A to F1
9 $\mu$ s	18 $\mu$ s	0 to 2 $\mu$ s	60 $\mu$ s	80 $\mu$ s

### Read Time Slot (Read Zero)

The read zero time slot is a read time slot that reads a 0-bit from the 1-Wire line. **Figure 5** shows the 1-Wire waveform. To generate the read time slot, the DRIVE signal is activated for a duration from A to BR. Starting at A, the voltage on the 1-Wire ramps down to 0V. To send a 0-bit, a 1-Wire device starts pulling the 1-Wire line low after A but before BR. The voltage on the 1-Wire line, therefore, is first driven low by the 1-Wire master and then remains held at a logic low by one or more 1-Wire devices. When BR has occurred, the master pulldown is turned off. At CR the status on the 1-Wire is sampled. Since the bit read is a 0, the 1-Wire is sampled repeatedly. At D0 the 1-Wire device stops pulling the line low, which allows the voltage to rise. A subsequent sampling at E0 determines that the line has reached a logic-high level. Now the dynamic pullup is activated, lasting from F0 to G0. This quickly pulls the 1-Wire line to 5V. The next time slot or a reset/presence-detect sequence may begin at H0.

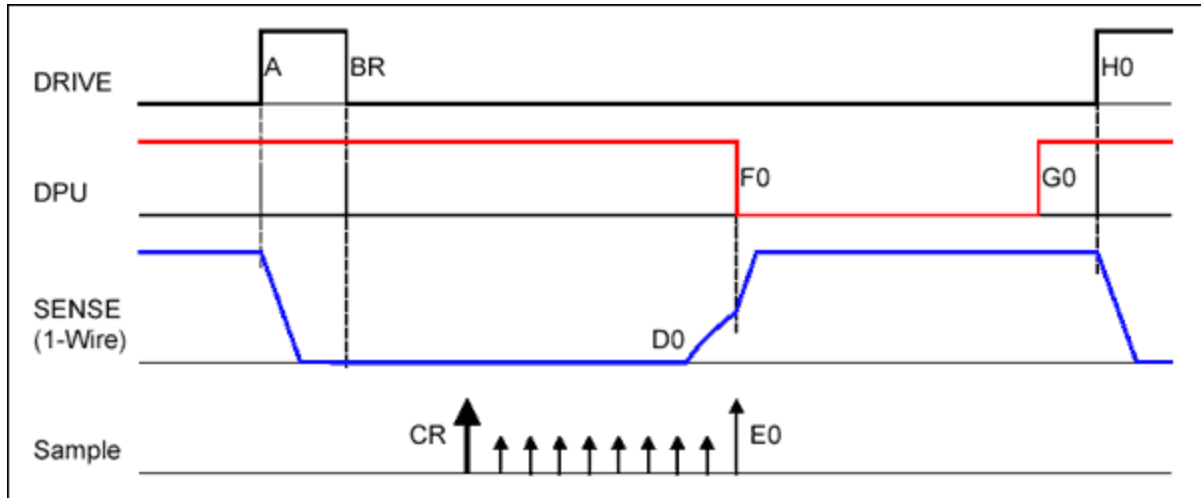

Figure 5. Read time slot (read zero).

The sampling point CR is the same as with the write one/read time slot. The distance between the subsequent sampling points should be as short as the microcontroller and software allow. The time from A to H0 is also referred to as time slot duration  $t_{SLOT}$ .

Table 4. Recommended Timing Values for Read Time Slot (Read Zero)				
A to BR	A to CR	E0 to F0	CR to G0	A to H0
9 $\mu$ s	18 $\mu$ s	0 to 2 $\mu$ s	60 $\mu$ s	82 $\mu$ s

## Practical Considerations

The structure of the signals that control the advanced 1-Wire network driver is relatively complex. The algorithms, however, are straightforward. For this reason, this driver is typically implemented in software, using a microcontroller that is fast enough to generate the signals in **real-time**. The flow charts given below assist in implementing the advanced driver using any suitable microcontroller that the user is familiar with. The execution time of every command at the user-specified crystal frequency must be taken into account to generate the proper timing.

## Software Flow Charts

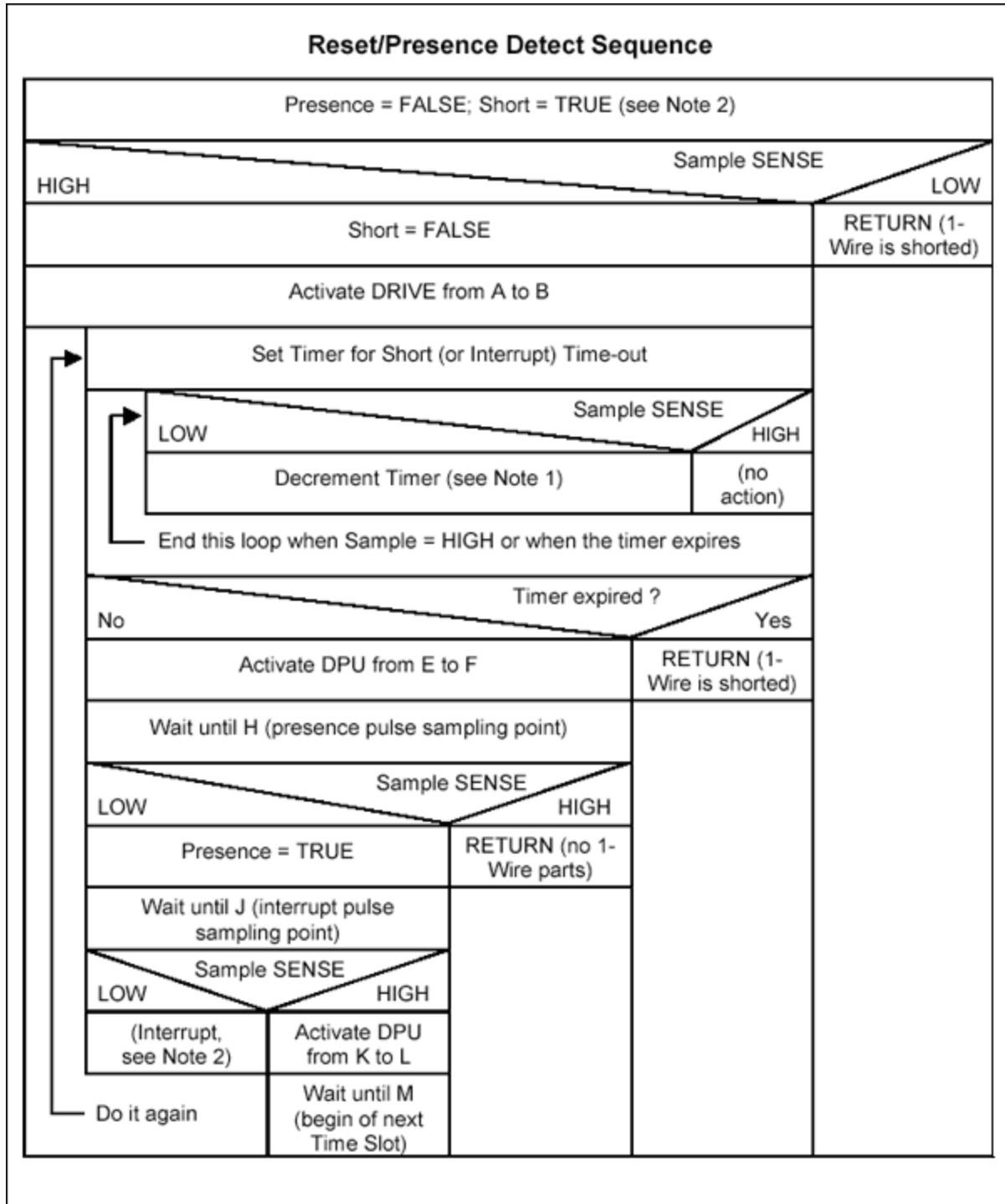

**Note 1:** Decrementing is necessary only if the timer is implemented as a counter rather than a real timer. The timer should expire after 5000µs.

**Note 2:** *Presence* and *Short* are logical variables that report to the superordinated program the result of the reset/presence-detect sequence. Interrupt is not reported as a variable since there is only one 1-Wire chip that can generate interrupts (DS1904 and DS2417) and the use of interrupts can considerably



reduce the effective speed of a 1-Wire network.

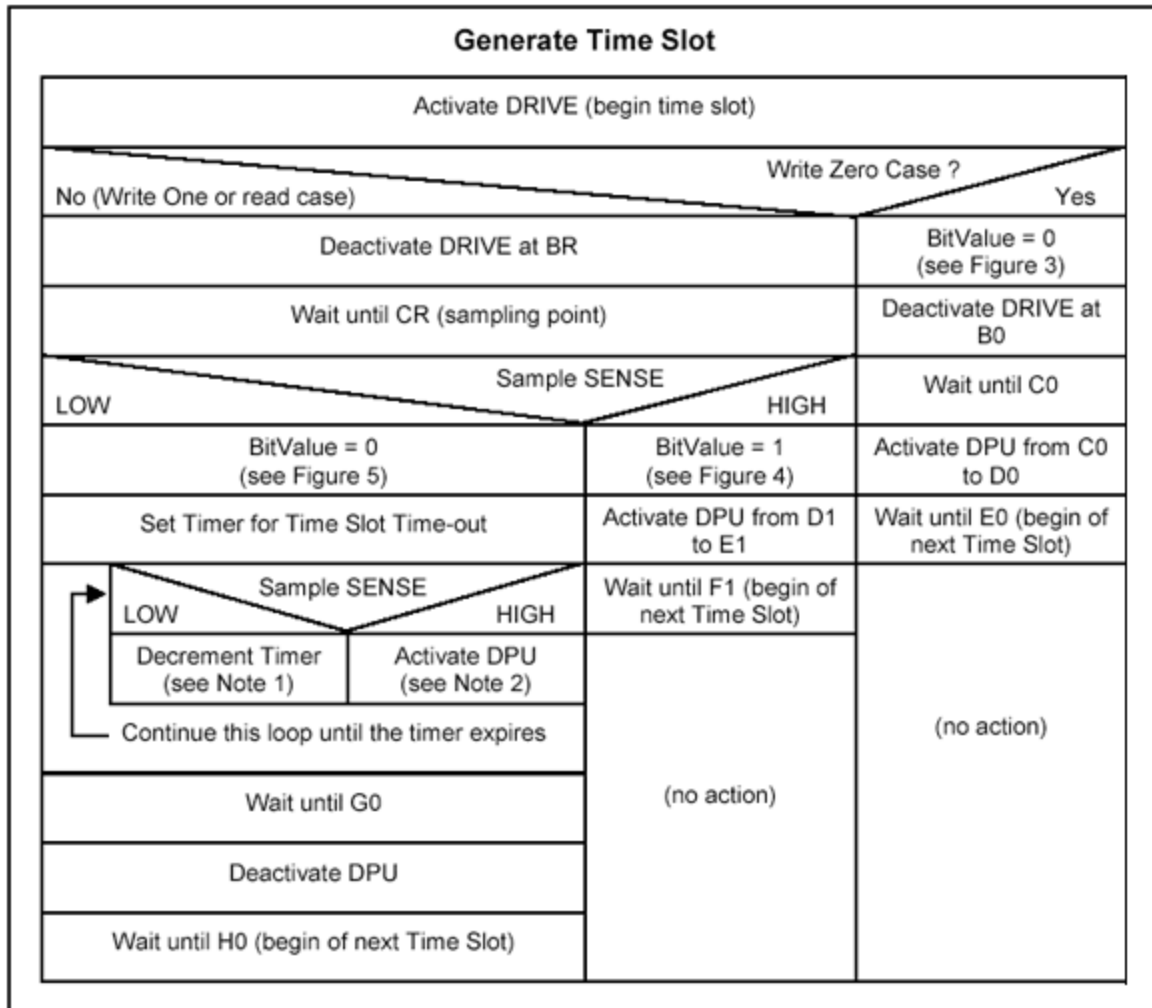

This flow chart assumes that there is a logical input variable that controls whether to generate a write zero or read time slot. The write one time slot is the same as a read time slot. The bit variable BitValue reports the result of the time slot to the superordinated program.

**Note 1:** Decrementing is necessary only if the timer is implemented as a counter rather than a real timer. The timer should expire after 45µs.

**Note 2:** According to the flow chart, DPU is repeatedly activated before the timer expires. This is acceptable since activating a signal that is already active does not change the state of that signal. If desired, one can test whether DPU is already active, and if so, not activate it again while performing the loop.

## Performance Examples

The scope traces on the next page show 1-Wire signals generated by the driver as described in this document. When verifying the signals, especially at the far end of a cable, it is necessary to use a

differential probe, leaving the probe's ground reference floating. Otherwise the probe's ground connection would bypass the 1-Wire ground reference and change the topology of the system. If a differential probe is not available, one must isolate the oscilloscope-ground from mains-ground through a transformer or use a battery-operated oscilloscope. Alternatively one could disconnect the safety ground of the oscilloscope's power-supply cable.

## Scope Traces

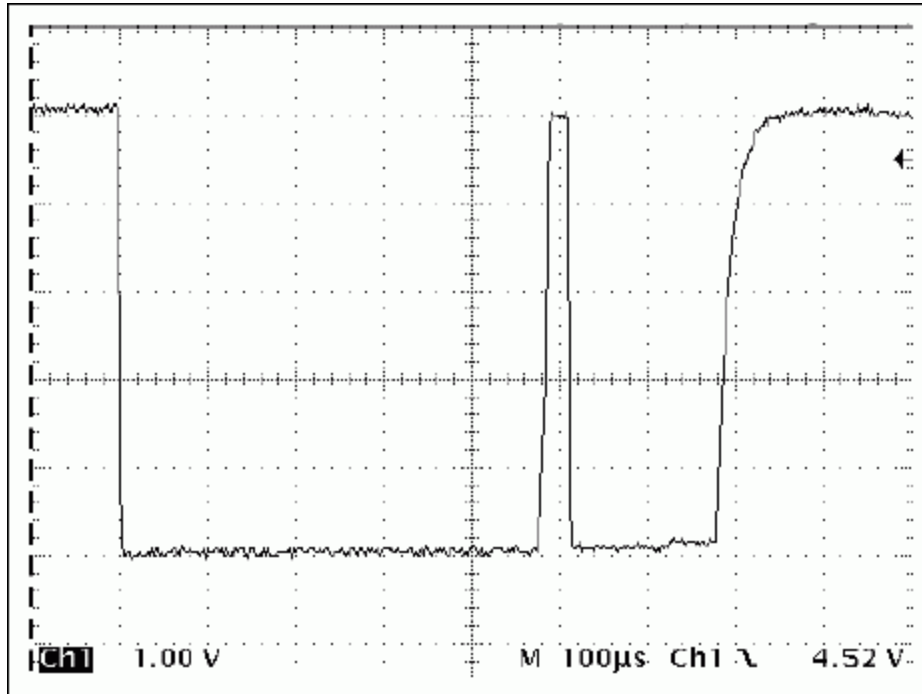

*Reset/Presence Detect Sequence (as in Figure 2).*

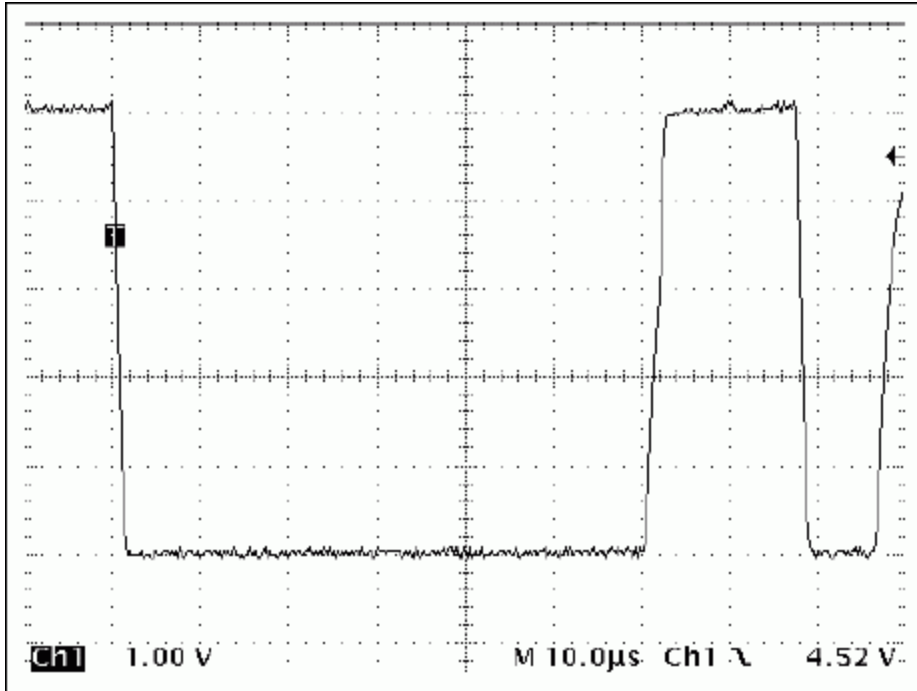

Write Zero Time Slot (as in Figure 3).

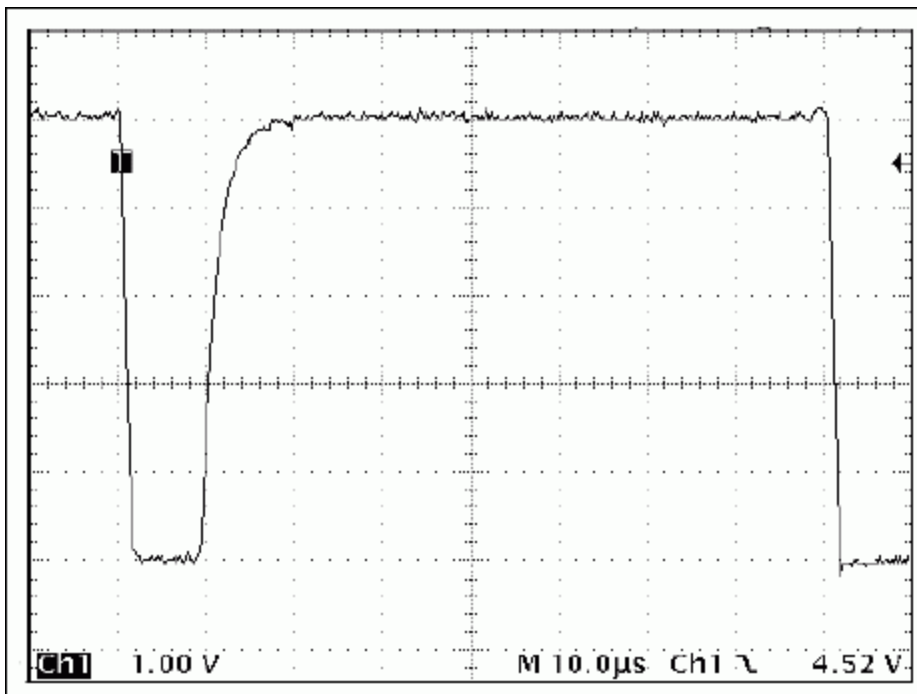

Write One/Read One Time Slot (as in Figure 4).

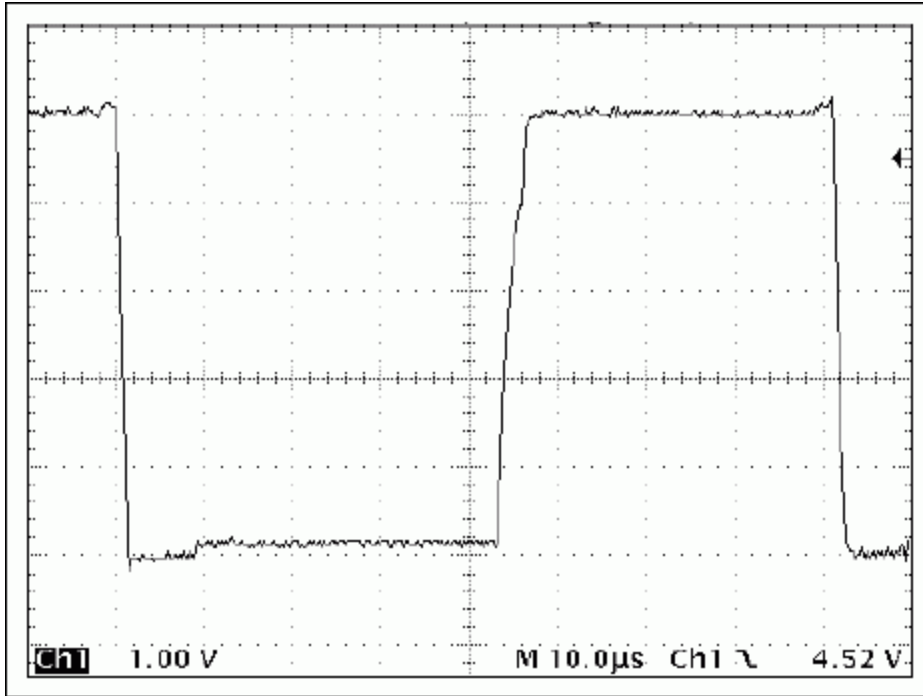

*Read Zero Time Slot (as in Figure 5).*

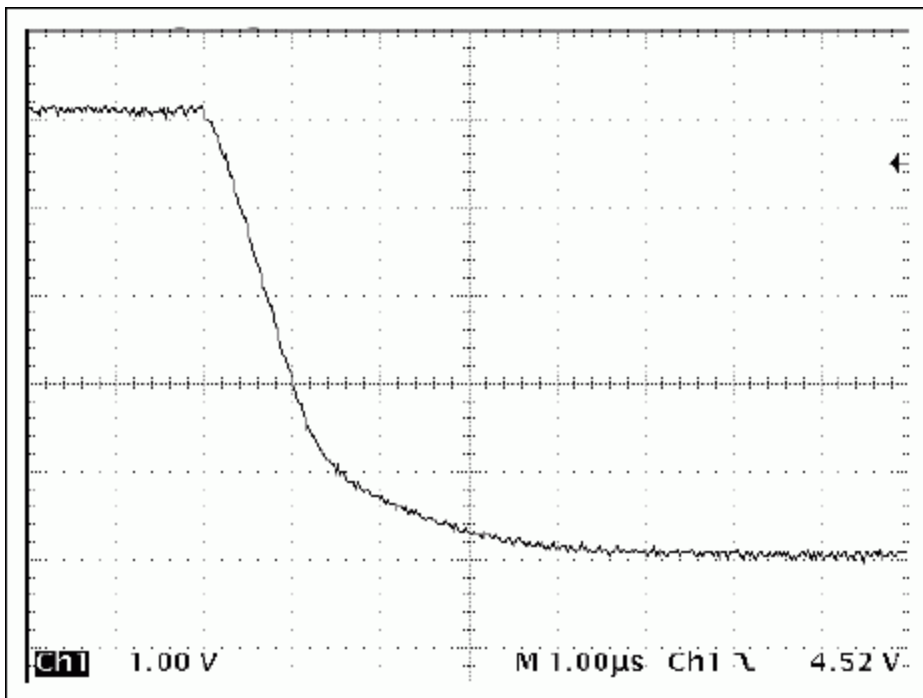

*Falling edge at the far end of a 300m cable.*

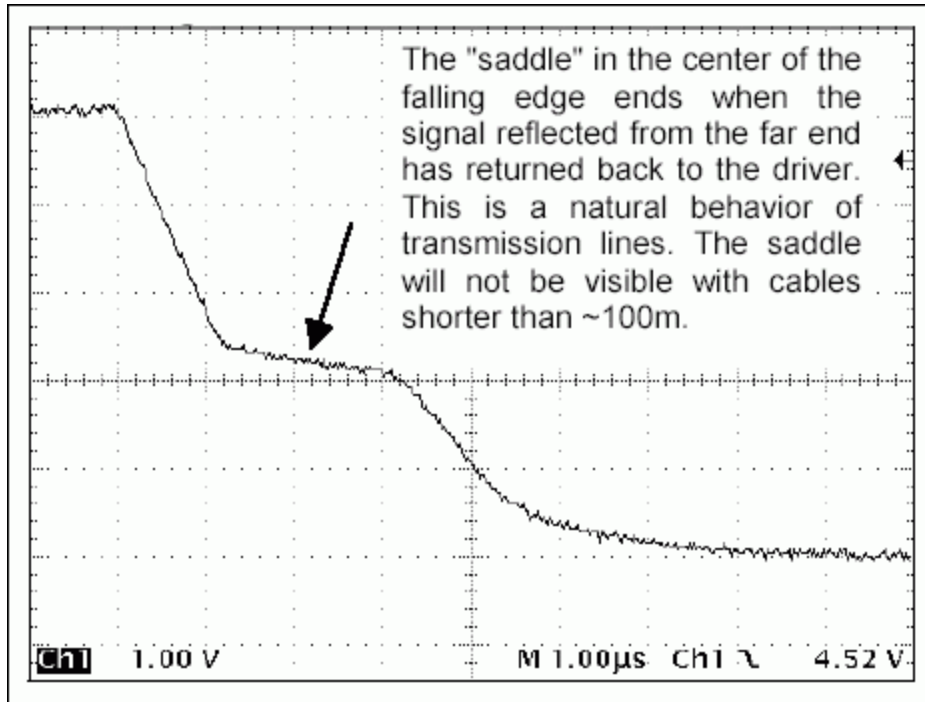

Same edge seen at the near end of the 300m cable.

**Note:** A product similar to the *Advanced 1-Wire Line Driver* is manufactured by Southwind Enterprises. See <http://ibuttonlink.com/> for technical details and ordering information.

1-Wire is a registered trademark of Maxim Integrated Products, Inc.

Related Parts		
DS1822	Econo 1-Wire Digital Thermometer	<a href="#">Free Samples</a>
DS18B20	Programmable Resolution 1-Wire Digital Thermometer	<a href="#">Free Samples</a>
DS18B20-PAR	1-Wire Parasite-Power Digital Thermometer	
DS18S20	1-Wire Parasite-Power Digital Thermometer	<a href="#">Free Samples</a>
DS18S20-PAR	Parasite-Power Digital Thermometer	
DS1904	iButton RTC	<a href="#">Free Samples</a>
DS1920	iButton Temperature Logger	
DS1921G	Thermochron iButton Device	
DS1921H	High-Resolution Thermochron iButton Devices	
DS1921Z	High-Resolution Thermochron iButton Devices	
DS1961S	iButton 1Kb EEPROM with SHA-1 Engine	

DS1963S	iButton Monetary Device with SHA-1 Function	
DS1971	iButton 256-Bit EEPROM	
DS1973	iButton 4Kb EEPROM	Free Samples
DS1982	iButton 1Kb Add-Only	Free Samples
DS1982U	UniqueWare iButton Device	
DS1985	iButton 16Kb Add-Only	Free Samples
DS1986	iButton 64Kb Add-Only	
DS1990A	iButton Serial Number	Free Samples
DS1992	iButton 1Kb/4Kb Memory	Free Samples
DS1993	iButton 1Kb/4Kb Memory	Free Samples
DS1994	iButton 4Kb Memory Plus Time	
DS1995	iButton 16Kb Memory	Free Samples
DS1996	iButton 64Kb Memory	Free Samples
DS2401	Silicon Serial Number	Free Samples
DS2404	EconoRAM Time Chip	
DS2405	Addressable Switch	
DS2406	Dual Addressable Switch Plus 1Kb Memory	Free Samples
DS2415	1-Wire Time Chip	
DS2417	1-Wire Time Chip With Interrupt	Free Samples
DS2432	1Kb Protected 1-Wire EEPROM with SHA-1 Engine	Free Samples
DS2433	4Kb 1-Wire EEPROM	
DS2450	1-Wire Quad A/D Converter	
DS2502	1Kb Add-Only Memory	Free Samples
DS2505	16Kb Add-Only Memory	Free Samples
DS2506	64Kb Add-Only Memory	
MAX31820	1-Wire Ambient Temperature Sensor	Free Samples
MAX31820PAR	1-Wire Parasite-Power, Ambient Temperature Sensor	
MAX31826	1-Wire Digital Temperature Sensor with 1Kb Lockable EEPROM	Free Samples

---

**More Information**

For Technical Support: <http://www.maximintegrated.com/support>  
For Samples: <http://www.maximintegrated.com/samples>  
Other Questions and Comments: <http://www.maximintegrated.com/contact>

---

Application Note 244: <http://www.maximintegrated.com/an244>  
REFERENCE SCHEMATIC 244, AN244, AN 244, APP244, Appnote244, Appnote 244  
© 2013 Maxim Integrated Products, Inc.  
Additional Legal Notices: <http://www.maximintegrated.com/legal>