



[Maxim](#) > [Design Support](#) > [Technical Documents](#) > [Application Notes](#) > [Digital Potentiometers](#) > APP 4135
[Maxim](#) > [Design Support](#) > [Technical Documents](#) > [Application Notes](#) > [Power-Supply Circuits](#) > APP 4135

Keywords: CCFL, analog dimming, lamp current amplitude modulation, DS3994, DS3992, DS3988, DS3991

APPLICATION NOTE 4135

Implementing Analog Dimming on the DS39xx CCFL Controllers

By: Shoumin Liu
Dec 14, 2007

Abstract: The DS3881, DS3882, DS3988, DS3991, DS3992 and DS3994 are controllers for cold-cathode fluorescent lamps (CCFLs) that backlight liquid crystal displays (LCDs). To achieve satisfactory visual results or conserve lamp life, dimming is required in most applications. This application note first introduces the two dimming approaches commonly used for CCFLs. It then describes how to implement analog dimming on the DS39xx CCFL controllers.

CCFL Dimming Methods

There are two common methods to dim CCFLs: burst dimming, which is also called PWM dimming or digital dimming, and analog dimming. This article discusses the advantages and disadvantages of each method.

Burst dimming turns the CCFLs on and off at a certain frequency, which is called the PWM dimming frequency. If the PWM dimming frequency is greater than 60Hz, the human eye cannot detect that the CCFLs are switching on and off. During the high period of the PWM cycle, the CCFLs are turned on and work at the lamp frequency. During the low period of the PWM cycle, the CCFLs are turned off and no current flows through them. By adjusting the duty cycle of the PWM pulses, one can thus increase or decrease the brightness of the CCFLs. The principal advantage of burst dimming is that it can achieve a very large dimming ratio. In some applications, however, the PWM dimming frequency may interfere with the vertical synchronous frequency of the display signals, thereby causing visible effects on the screen. Burst dimming can also cause audible transformer noise.

Instead of turning on the CCFLs in bursts, analog dimming keeps the CCFLs on continuously. Lamp brightness is adjusted by varying the lamp current amplitude. Obviously, a greater current amplitude results in a brighter CCFL, and a lower amplitude renders a dimmer CCFL. Analog dimming has a very narrow dimming range, which is insufficient in some applications. But analog dimming does not cause any audible transformer noise, since the PWM frequency is not present. Analog dimming, moreover, does not interfere with the vertical synchronous frequency.

Table 1 compares analog dimming and burst dimming. More information can be found in the Application Note 3997: [How to Achieve a 300:1 Dimming Ratio with the DS3881/DS3882 CCFL Controllers](#).

Table 1. Analog Dimming and Burst Dimming Compared

Analog Dimming	Burst Dimming
1. Narrow dimming range, no more than 3:1	1. Large dimming ratio up to 100:1
2. No audible transformer noise	2. Audible transformer noise can be present.
3. No interference with the vertical synchronous frequency	3. The PWM dimming frequency can interfere with the vertical synchronous frequency.

Implementing CCFL Analog Dimming

The [DS3881](#) and [DS3882](#) CCFL controllers have built-in analog dimming control functionality. The user can adjust the lamp current by using the I²C interface to set the BLC register.

The [DS3988](#), [DS3991](#), [DS3992](#), and [DS3994](#) CCFL controllers feature burst dimming. However, with the simple external circuitry illustrated in **Figure 1**, these DS39xx controllers can support analog dimming effectively.

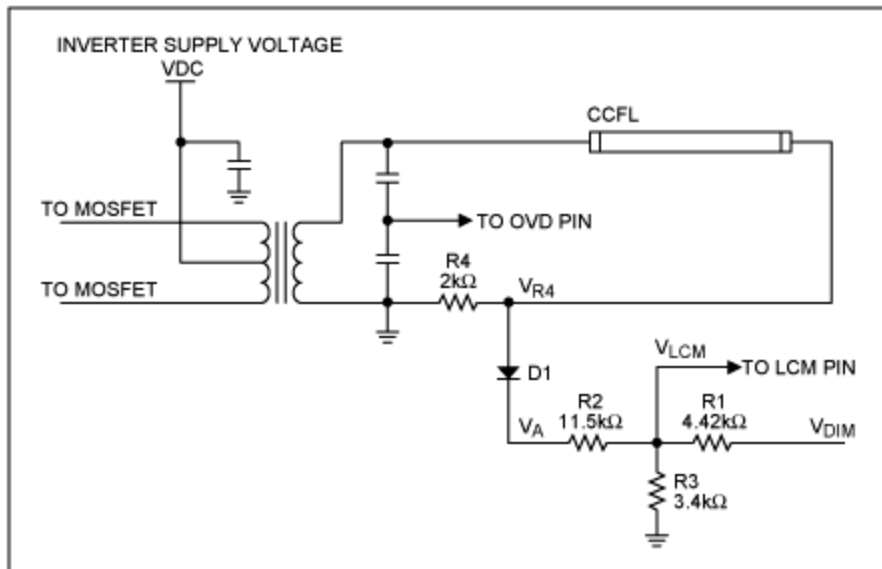

Figure 1. External circuitry required to implement analog dimming on the DS39xx CCFL controllers.

In Figure 1, R4 is the lamp-current feedback resistor. The peak voltage level across R4 is V_{R4} . After the signal passes the diode, the peak voltage level becomes V_A . The peak voltage level at the LCM input, V_{LCM} , is the linear combination of V_A and the analog dimming control voltage, V_{DIM} . Therefore:

$$V_{LCM} = aV_{DIM} + bV_A \quad (\text{Eq. 1})$$

where

$$a = \frac{R2R3}{R1R2 + R1R3 + R2R3} \quad (\text{Eq. 2})$$

and

$$b = \frac{R1R3}{R1R2 + R1R3 + R2R3} \quad (\text{Eq. 3})$$

V_{LCM} (peak value) is 2.35V nominal. So V_{DIM} determines V_A , which is directly related to the lamp current. Note that if R1 is left open and V_{DIM} is not available, the circuitry is virtually part of the typical multilamp current monitor circuitry presented in the DS3992/DS3994 data sheets.

Calculating Resistor Values

To calculate the resistor values, use the system requirements and Equation 1 to obtain a and b . Then use Equations 2 and 3 to calculate the appropriate values for R1, R2, and R3.

For example, if an application requires that the lamp current be 7mA_{RMS} when V_{DIM} is 0V and 3mA_{RMS} when V_{DIM} is 3.3V, then V_A equals 19.1Vpk ($\sqrt{2} \times 7mA_{RMS} \times 2k\Omega - 0.7V$) when $V_{DIM} = 0V$, and V_A equals 7.8Vpk ($\sqrt{2} \times 3mA_{RMS} \times 2k\Omega - 0.7V$) when $V_{DIM} = 3.3V$. Using these conditions and Equation 1, one can determine that $a = 0.422$ and $b = 0.123$.

With a and b known, now set R3 with an arbitrary value (no more than 10k Ω). Then solve Equations 2 and 3 for R1 and R2. If R3 is chosen as 3.4k Ω , then R1 = 3.65k Ω and R2 = 12.4k Ω . Since there are harmonics in the lamp current, the crest factor of the current waveform is not always $\sqrt{2}$. Thus some adjustments for the resistor values are needed to achieve the desired results. In this case, the final values of R1 and R2 are 4.42k Ω and 11.5k Ω , respectively.

In the application described above, the lamp current decreases as the dimming control voltage increases. This function is called negative-slope dimming. Conversely, positive-slope dimming means that the lamp current increases as the dimming control voltage increases. If positive-slope dimming is desired, an inverting circuit can be added between V_{DIM} and R1.

Measured Waveforms

Figures 2 and 3 show the measured lamp-current waveforms based on the circuitry in Figure 1. Figure 2 is captured at $V_{DIM} = 0V$ and Figure 2 at $V_{DIM} = 3.3V$. The dimming ratio in this case is 2.33:1.

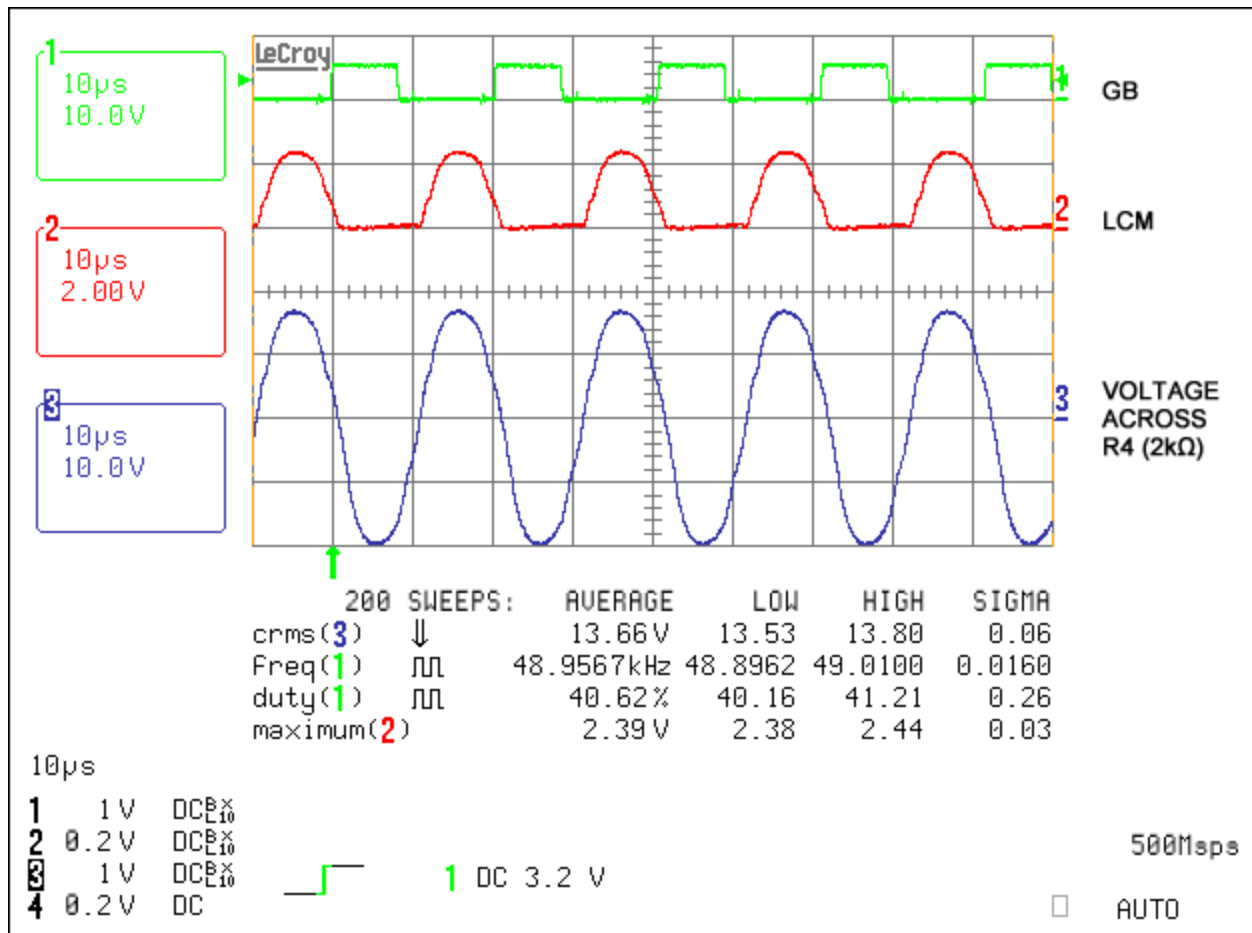

Figure 2. Lamp current waveforms at $V_{DIM} = 0V$.

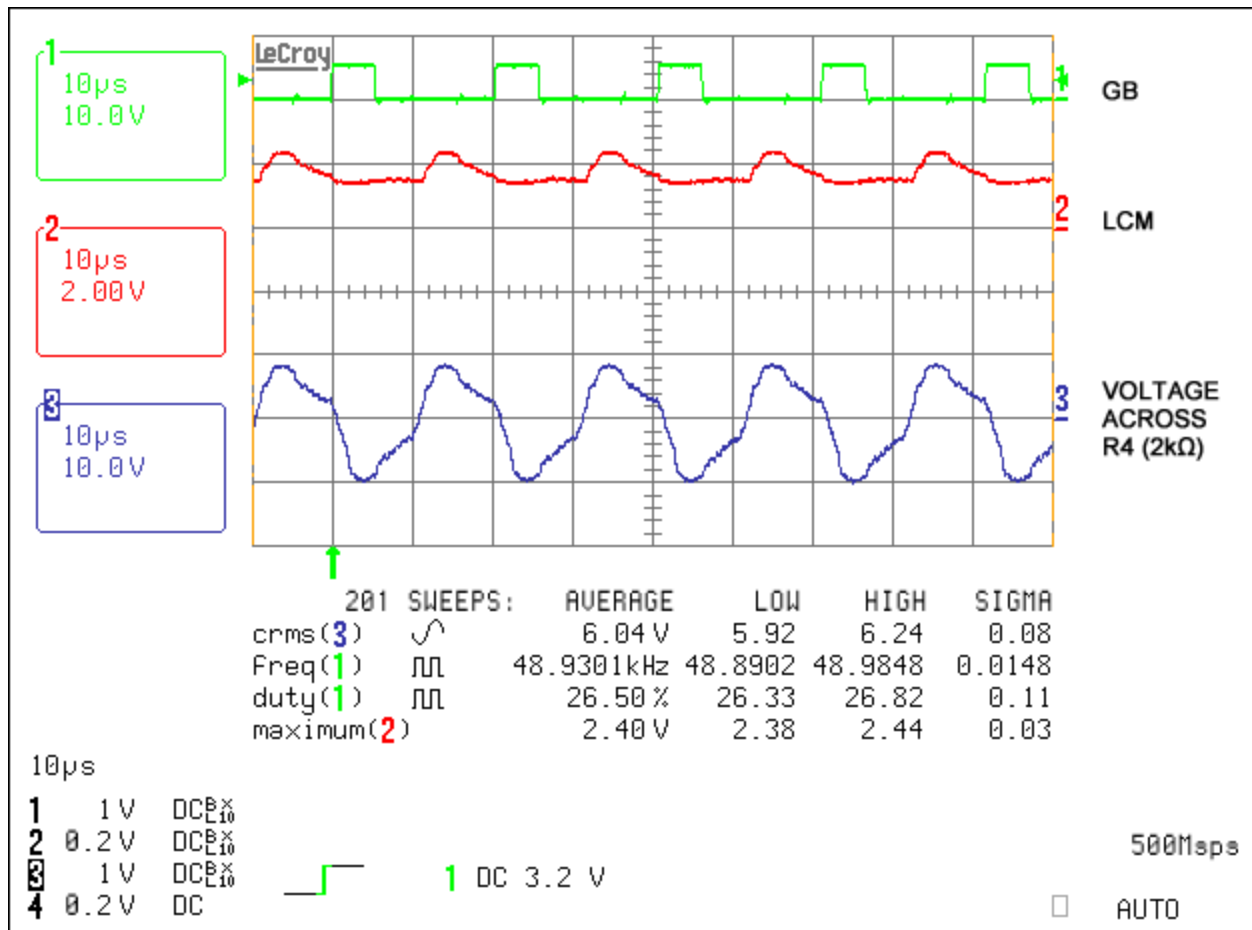

Figure 3. Lamp current waveforms at $V_{DIM} = 3.3V$.

Related Parts

DS3881	Single-Channel, Automotive CCFL Controller	
DS3882	Dual-Channel Automotive CCFL Controller	
DS3988	8-Channel Cold-Cathode Fluorescent Lamp Controller	
DS3991	Low-Cost CCFL Controller	Free Samples
DS3992	Two-Channel, Push-Pull CCFL Controller	Free Samples
DS3994	4-Channel Cold-Cathode Fluorescent Lamp Controller	Free Samples

More Information

For Technical Support: <http://www.maximintegrated.com/support>

For Samples: <http://www.maximintegrated.com/samples>

Other Questions and Comments: <http://www.maximintegrated.com/contact>

Application Note 4135: <http://www.maximintegrated.com/an4135>

APPLICATION NOTE 4135, AN4135, AN 4135, APP4135, Appnote4135, Appnote 4135

Copyright © by Maxim Integrated Products
Additional Legal Notices: <http://www.maximintegrated.com/legal>