



[Maxim](#) > [Design Support](#) > [Technical Documents](#) > [Application Notes](#) > [Amplifier and Comparator Circuits](#) > APP 4030
[Maxim](#) > [Design Support](#) > [Technical Documents](#) > [Application Notes](#) > [Miscellaneous Circuits](#) > APP 4030

Keywords: Analog multiplier, current sense

APPLICATION NOTE 4030

Analog Multiplier Improves the Accuracy of High-Side Current-Sense Measurements

By: **Maurizio Gavardoni**, Product Definer
Jun 02, 2008

Abstract: This application note shows how to use an analog multiplier integrated with a high-side current-sense amplifier to measure battery charge and discharge currents in portable equipment and notebook computers. The circuit presented improves the measurement accuracy by feeding the ADC reference voltage to one of the analog multiplier's inputs.

Introduction

High-side current-sense amplifiers are used in a wide variety of applications where reliability and accuracy are paramount concerns. In computer notebooks these devices monitor the battery's charge and discharge currents, as well as currents in USB ports and many other supply rails that may need to be powered down to control heating and power dissipation. High-side current-sense amplifiers are used in portable consumer equipment to monitor the charge and discharge currents of the Li+ battery. These amplifiers not only monitor the battery current in automotive applications, but can also perform motor control or GPS antenna detection. Finally, in base stations high-side current-sense amplifiers monitor the current of power amplifiers.

In many applications, high-side current-sense amplifiers directly interface with analog-to-digital converters (ADCs). Some of these ADCs use an external reference voltage to determine the full-scale input range, and the accuracy of that measurement depends on the precision of the reference voltage.

This application note shows how to use an analog multiplier integrated with a high-side current-sense amplifier to measure battery charge and discharge currents in a wide range of applications. This design approach improves the measurement accuracy by feeding the ADC's reference voltage to one of the analog multiplier's inputs.

High-Side vs. Low-Side Current Measurement Techniques

There are two common design approaches for measuring current: a high-side and a low-side technique. A high-side current-measurement scheme employs a sense resistor connected in series between the voltage source (e.g., a battery) and the load. In contrast, measurements taken with the low-side scheme employ a sense resistor in series to the ground path. The low-side scheme presents two significant disadvantages not shared by the high-side counterpart. Firstly, in the low-side design if the load is accidentally shorted to ground, then the current-sense amplifier is bypassed and cannot detect the short.

Secondly, the low-side scheme introduces an undesirable resistance in the ground path, thus creating a split ground plane. The high-side approach does have a disadvantage: the current-sense amplifier must be able to sustain a possible high-voltage common-mode input (depending on how high the voltage source is). The low-side scheme can be achieved by a simple op-amp, as long as it has common-mode input with ground-sensing capability. The high-side scheme is typically designed around current-sense amplifiers.

Power Measurement with a High-Side Current-Sense Amplifier

The [MAX4211](#) is a high-side current-sense amplifier with integrated analog multiplier. This device measures the power delivered to a load, as illustrated in **Figure 1**. The power delivered to the load is defined as the product of the load voltage and the load current. The high-side current sensor provides a voltage output proportional to the current in the load. This voltage is fed to the analog multiplier whose other input directly senses the voltage at the load. The output of the analog multiplier is a voltage proportional to the power of the load.

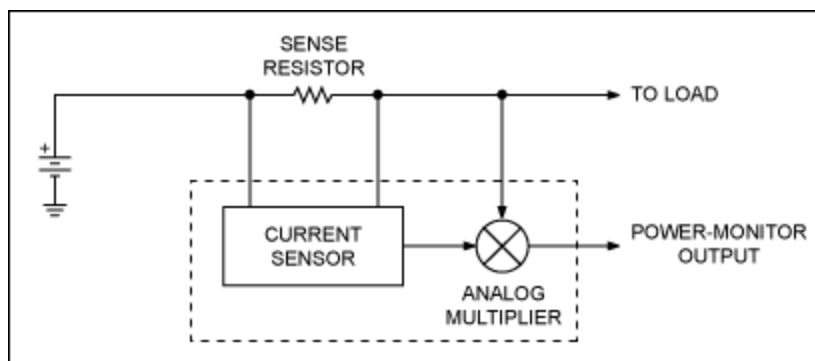

Figure 1. In this design the MAX4211 multiplies load current and load voltage to provide an analog output voltage proportional to the power consumed by a load.

Alternate Use of Analog Multipliers in High-Side Current-Sense Amplifiers

There is another way to use the analog multiplier. Instead of connecting the analog multiplier's external input to the voltage of the load, connect it to the ADC's external reference voltage. In this design the analog multiplier is not measuring power, but is relating the voltage output of the current-sense amplifier to the ADC's reference voltage.

Figure 2 shows this application where the MAX4211 measures the battery charge and discharge currents. The voltage output, P_{OUT} , is fed to a 16-bit ADC with an input voltage range from 0 to V_{REF} . Here V_{REF} is provided by an external voltage regulator and should be between 1.2V and 3.8V (3.8V in this application example). The analog multiplier input accepts a voltage between 0 and 1V, so the two resistors, R1 and R2, divide the 3.8V reference voltage. Assuming that $R2 = 1k\Omega$ and $R1 = 2.8k\Omega$, then $V_{IN} = 1V$. The MAX4211 has gain of 25 and a sense voltage range (V_{SENSE}) from 0 to 150mV, which produces an output voltage at both P_{OUT} and I_{OUT} between 0 and 3.75V (proportional to the current that flows on the load).

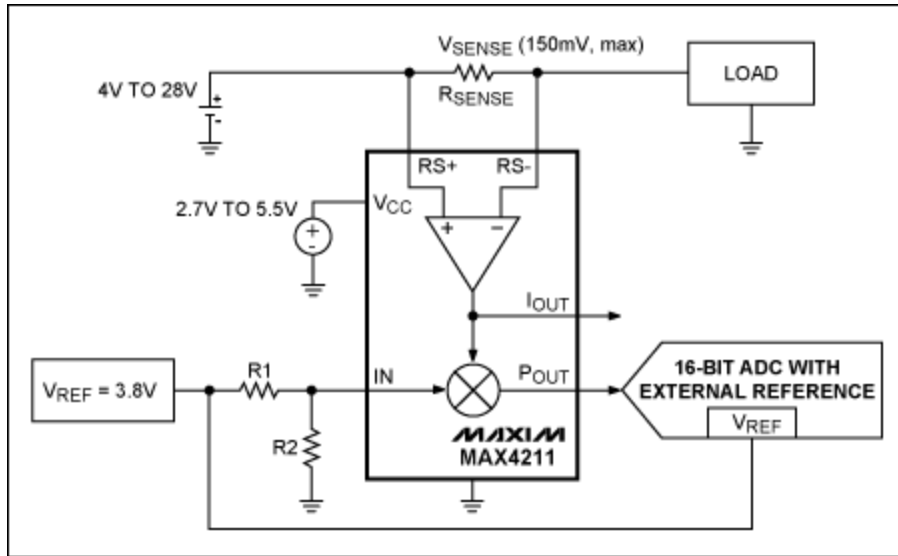

Figure 2. In this design the MAX4211 uses an ADC with external reference voltage to measure the battery charge and discharge currents.

Figure 3 shows the same application with an ADC that has an internal voltage reference. The application presented here applies when the ADC's voltage reference is either internal or external.

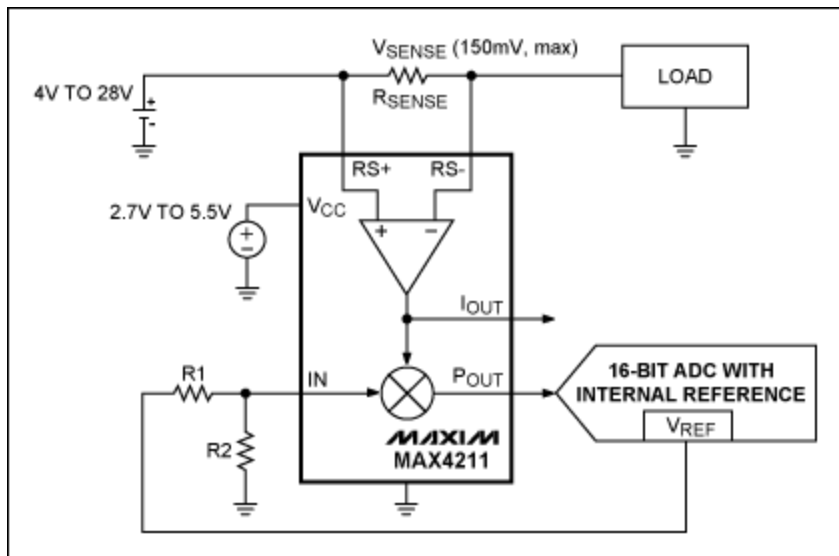

Figure 3. In this design the MAX4211 uses an ADC with internal reference voltage to measure the battery charge and discharge currents.

There is an advantage to using the P_{OUT} output of the current-sense amplifier instead of the I_{OUT} output: the signal fed to the ADC (which is proportional to the current in the load) is scaled by the V_{REF} voltage. Note also, that using the P_{OUT} output can relax the accuracy requirements demanded by the voltage reference. This relaxed demand on the voltage reference happens because the digital code produced by the ADC depends on the ratio between its input signal and its reference voltage (which represents the full-scale value). The P_{OUT} output is a direct function of the reference voltage, therefore the ADC measurement is, in principle, independent of the accuracy of the reference voltage.

If the I_{OUT} were connected to the ADC, however, then the ADC would see any errors in the reference voltage as a full-scale error. The two equations below represent the ratio of ADC input to ADC full-scale, and illustrate this concept:

$$\frac{P_{OUT}}{V_{REF}} = I_{LOAD} \times R_{SENSE} \times 25 \times \frac{V_{REF} \times R2}{(R1 + R2)V_{REF}} = I_{LOAD} \times R_{SENSE} \times 25 \times \frac{R2}{(R1 + R2)} \quad [\text{Eq. 1}]$$

$$I_{OUT}/V_{REF} = I_{LOAD} \times R_{SENSE} \times 25/V_{REF} \quad [\text{Eq. 2}]$$

Equation 1, which uses the P_{OUT} output, is not dependant on the accuracy of V_{REF} . Equation 2, which uses the I_{OUT} output, produces an error that is the inverse function of the V_{REF} accuracy.

The overall accuracy of the system shown in Figures 2 and 3 depends on many factors: resistor tolerance, the amplifier's gain error, voltage offset and bias current, reference voltage accuracy, ADC errors, and the drift versus temperature of all the above. The solution presented in Figures 2 and 3 uses the analog multiplier of the MAX4211 to improve the system accuracy by eliminating one of the causes of errors—the inaccuracy of the reference voltage.

There are at least three sources of errors that can affect V_{REF} accuracy:

1. Initial DC error (percentage of the nominal value)
2. The V_{REF} value changes with the load
3. V_{REF} value changes over temperature

Figure 4 illustrates the second error source listed above: a heavy load is connected to V_{REF} and its value drops from 3.8V to 1.2V when the load is increased. P_{OUT} matches the V_{REF} drop profile and changes accordingly.

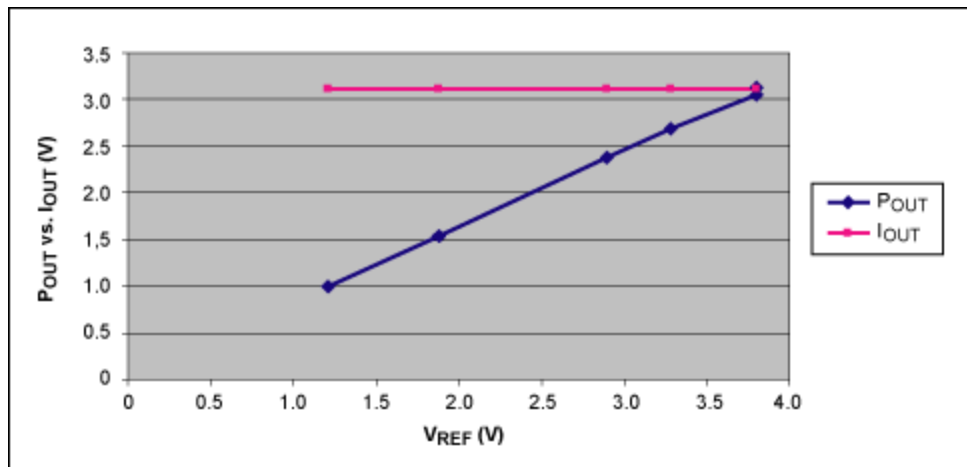

Figure 4. Data illustrate how V_{REF} changes with the load. Here P_{OUT}/I_{OUT} vs. V_{REF} with $V_{SENSE} = 125mV$.

The following **Figures 5, 6** and **7** show V_{REF} and the MAX4211's outputs changing with temperature. Here V_{SENSE} is kept constant at 100mV and V_{CC} is 5V. The temperature of the circuit for Figure 2 varies from $-40^{\circ}C$ to $+85^{\circ}C$ (with intermediate steps at $-20^{\circ}C$, $0^{\circ}C$, $+25^{\circ}C$, $+45^{\circ}C$ and $+65^{\circ}C$). Figure 5 shows the profile of V_{IN} over temperature (as a consequence of V_{REF} 's drift over temperature).

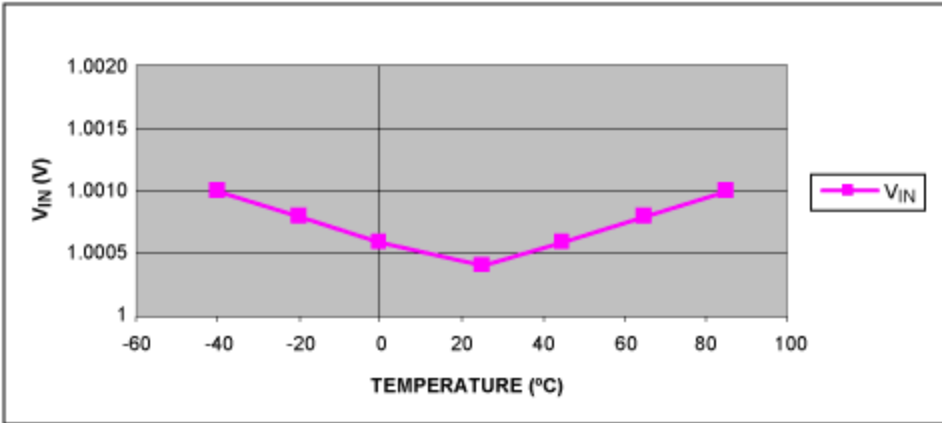

Figure 5. V_{IN} vs. temperature.

Figure 6 shows the profile of the MAX4211's I_{OUT} versus the ratio of I_{OUT}/V_{IN} , which is proportional to the ADC's input-signal/full-scale ratio (in the hypothetical case where the ADC was driven by I_{OUT}).

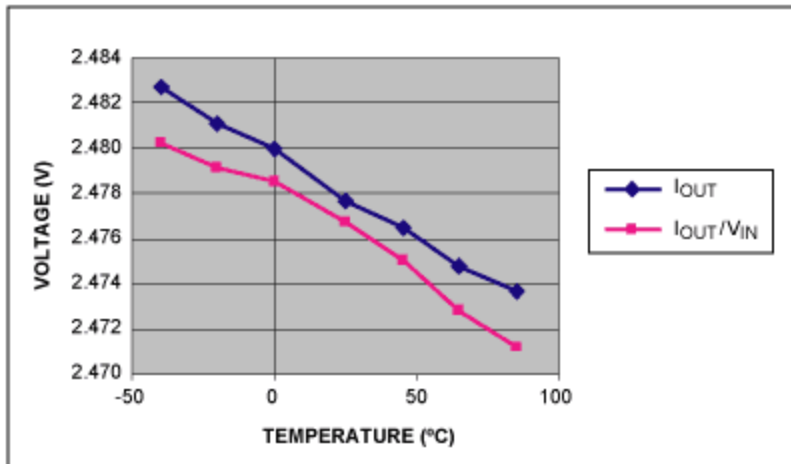

Figure 6. I_{OUT} vs. I_{OUT}/V_{IN} with $V_{SENSE} = 100mV$.

It is very evident that the I_{OUT}/V_{IN} ratio is dependent on the V_{IN} profile of Figure 5. The dip between 0°C and +45°C of V_{IN} in Figure 5 is reflected as a hump around the same temperature range in the I_{OUT}/V_{IN} profile of Figure 6. The ADC measurement is affected by the changes of the voltage reference, V_{REF} , with the temperature.

Finally, Figure 7 shows the profile of the MAX4211's P_{OUT} versus the ratio of P_{OUT}/V_{IN} . Again, P_{OUT}/V_{IN} is proportional to the ADC's input-signal/full-scale ratio.

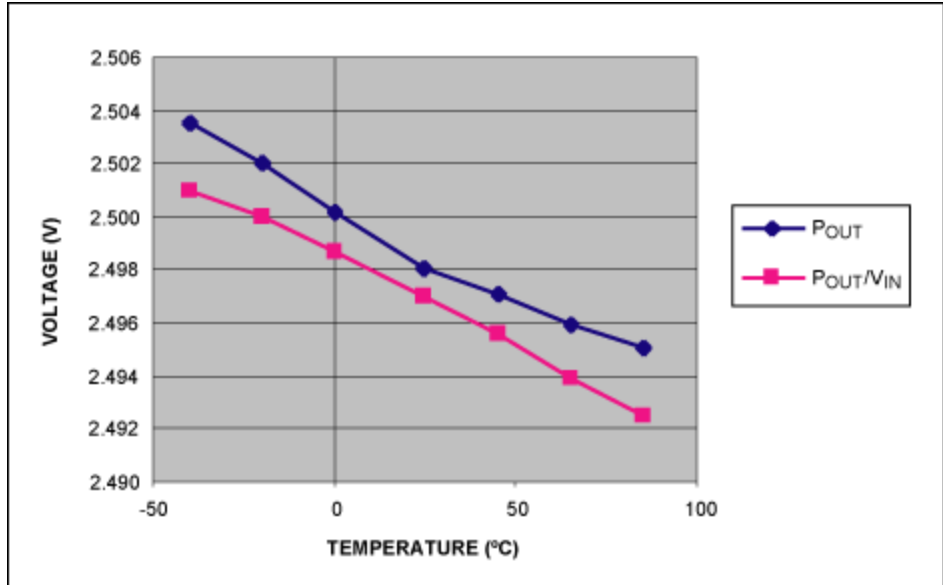

Figure 7. P_{OUT} vs. P_{OUT}/V_{IN} with $V_{SENSE} = 100mV$.

Figure 7 shows how the ratio of P_{OUT}/V_{IN} is independent from the V_{IN} profile over temperature that is shown in Figure 5. The drop of V_{IN} between $0^{\circ}C$ and $+45^{\circ}C$ is already "absorbed" by the P_{OUT} output and does not appear in the P_{OUT}/V_{IN} ratio. The ADC measurement does not depend on the V_{REF} profile over temperature.

Figure 8 summarizes these concepts by showing both I_{OUT}/V_{IN} and P_{OUT}/V_{IN} together with their ideal linear trend lines.

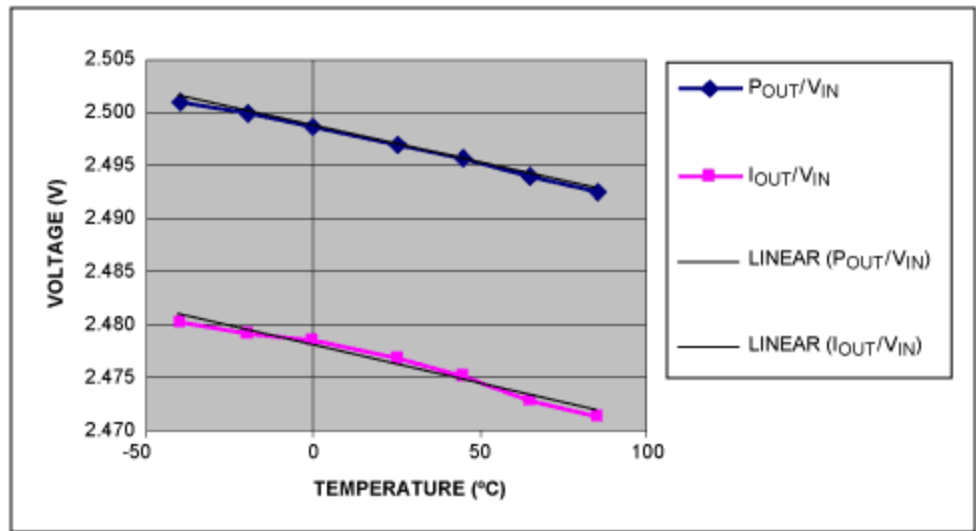

Figure 8. P_{OUT}/V_{IN} vs. I_{OUT}/V_{IN} with $V_{SENSE} = 100mV$.

Conclusion

The integrated analog multiplier of high-side current-sense amplifiers is typically used to measure the power at the load. There is, however, another possible application for this integrated multiplier. The current-sense amplifier can be connected to an ADC that uses either an internal or an external voltage

reference. In both cases, the overall accuracy of the measurement strongly depends on the accuracy of the voltage reference (V_{REF}). By multiplying the load current measurement with V_{REF} , the overall accuracy of the ADC measurement is no longer dependent on voltage reference errors. Using this alternate design, one can improve measurement accuracy even in the presence of a low-cost and less-accurate voltage reference.

A similar article appeared on the *ED website* on March 26, 2008.

More Information

For Technical Support: <http://www.maximintegrated.com/support>

For Samples: <http://www.maximintegrated.com/samples>

Other Questions and Comments: <http://www.maximintegrated.com/contact>

Application Note 4030: <http://www.maximintegrated.com/an4030>

APPLICATION NOTE 4030, AN4030, AN 4030, APP4030, Appnote4030, Appnote 4030

Copyright © by Maxim Integrated Products

Additional Legal Notices: <http://www.maximintegrated.com/legal>