



[Maxim](#) > [Design Support](#) > [Technical Documents](#) > [Application Notes](#) > [T/E Carrier and Packetized](#) > APP 1797

Keywords: pulse mask, T1, E1, T3, E3, template, transceiver, transmission, shape, amplitude, simulator, t1 e1, t3 e3

APPLICATION NOTE 1797

Measuring Telecom Systems Against a Pulse Mask Template

Dec 03, 2002

Abstract: Measuring T1/E1 and T3/E3 pulse masks and comparing them against specifications are discussed. A test fixture is utilized as an illustration.

In the telecommunication industry, it is often necessary to design equipment that interfaces with older, existing telecommunication systems. To ensure that a piece of equipment functions properly in a legacy system, several application-dependent specs are defined for manufacturers to follow. These specs pertain to data transfer, signal timing requirements, and functions that must be executed when data-transfer errors are detected.

Transmission signal quality specs are particularly important. The spec for how the transmission signal should appear depends on the type of system. The measured signal should fit within a predefined template called a pulse mask.

This article examines the specifications for T1, T3, E1, and E3 pulse masks and testing transmission signals for pulse mask compliance. It discusses some of the problems that can occur when testing multiport transmission devices.

Maxim has a line of multiport transceivers for T1/E1 systems and T3/E3 systems, as well as support hardware to make testing the pulse mask for multiport devices easier. Interface and pulse-mask specifications for T1/E1/T3/E3 networks follow.

Specifications for the digital networks were taken from the International Telecommunication Union (ITU) document G.703, October 1998, and the American National Standard for Telecommunications (ANSI) document ANSI T1.102-1993.

T1 Pulse-Mask Template

The first and most common digital transmission system in North America is a T1 network (1.544Mbps). This system of transmitting digital data was developed in the mid 1960s for public telephone providers. Since then, T1 networks changed their function from the transmission of strictly digital voice conversations to the transmission of the large data packets that are the core technology for applications such as wide area networks (WAN) and the Internet.

For each T1 line, the physical connection that a customer sees is always two twisted-pair lines: one for the transmit data and one for the receive data. Both are differential pairs terminated with a 100Ω

resistive load.

To measure the pulse mask, the transmit-data path is selected and measured at the end of the transmission line. Many T1 transceivers provide options to compensate for the resistive and capacitive loading of the transmission line by adjusting the amplitude of the T1 pulse. Maxim has T1 transceivers that can be configured for both short-haul (DSX-1) lines, which can be up to 655ft with 22 AWG cable, and long-haul (CSU) lines, which are rated to a maximum of -36dB of signal loss. This is normally referred to as the line build-out (LBO) of the transmission line. Within the short-haul (DSX-1) lines and long-haul (CSU) lines, Maxim T1 transceivers can be set for the proper LBO. T1 interface specifications for a pulse mask are found in **Table 1**.

Table 1. T1 Interface Specification for Pulse Mask

Interface Parameters	Specifications
Nominal Line Rate	1.544Mbps
Medium	One balanced twisted pair is used for each direction of transmission.
Isolated Pulse	A positive pulse that is preceded by four zeros and followed by one or more zeros.
Test-Load Impedance	A resistive test load of 100Ω ±5%.
Pulse Amplitude	The pulse amplitude for a positive isolated pulse is between 2.4V and 3.6V.
Pulse Shape	The shape of every pulse that approximates an isolated pulse conforms to the mask in Figure 1 . This shape is shown in a normalized form, with the nominal pulse amplitude shown as 1.0.

Regardless of how the T1 device is configured, the T1 signal must fit within the pulse mask at the end of the line when transmitting an isolated pulse. An isolated pulse is normally a positive pulse that is both preceded and followed by a certain number of zeros. The number of zeros required is determined by the spec ANSI T1.102-1993.

T1 pulse masks are normalized when displayed in graphical form with the nominal pulse amplitude of 1.0 inside the mask. The pulse amplitude is measured in the center of the pulse located at time T0 in Figure 1. If the amplitude at T0 is within 2.4V and 3.6V, the signal is scaled linearly to determine if it fits the pulse mask.

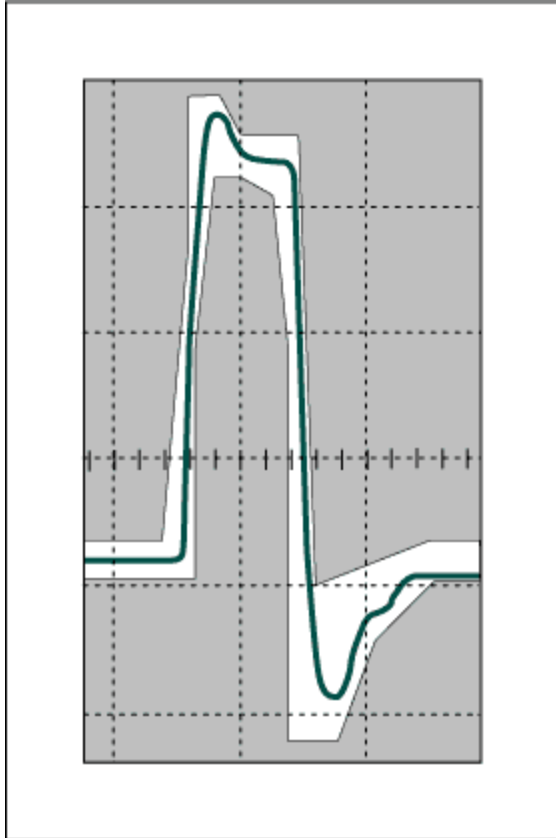

Figure 1. T1 pulse amplitude (1.544Mbps) is measured in the center of the pulse located at time T_0 .

E1 Pulse-Mask Template

There are other digital transmission systems besides T1 networks. One common system used widely in Europe and Asia is E1 (2.048Mbps). From a broad overview, E1 networks are similar to the T1 networks with some minor differences in the line rate and number of channels per frame. E1 networks still require two connectors (one used to transmit data, the other to receive data) and a resistive termination at the end of the line; the signals require that pulses meet a specified template. However, the spec for E1 requires that all the pulses meet the template and not just an isolated pulse (**Figure 2**).

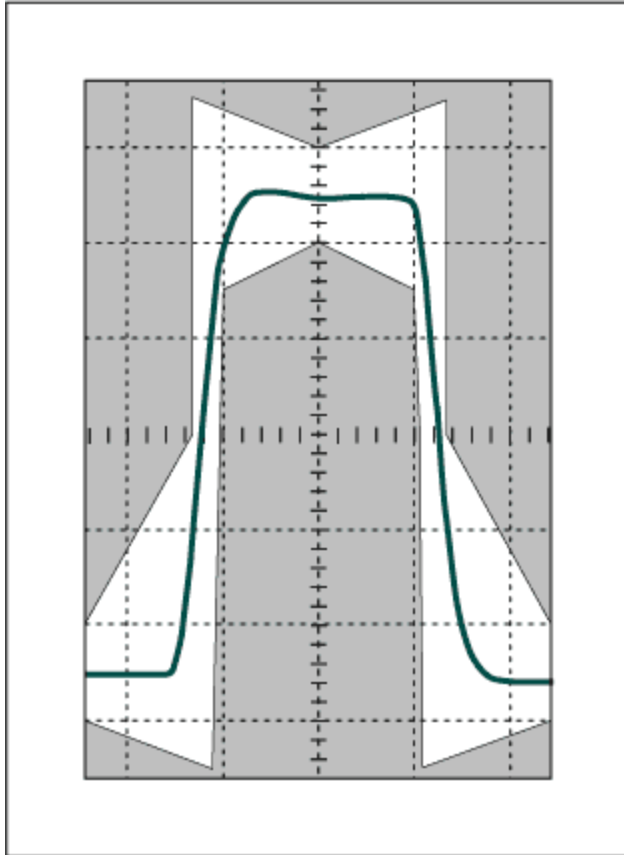

Figure 2. Every E1 pulse (2.048Mbps) must conform to the shape of the template and not just an isolated pulse.

E1 is tested at 0ft, or at the source of the E1 pulse, while T1 pulses must meet the template for the entire line length. Two types of cables are used in E1 mode: 75Ω coaxial cable and a 120Ω twisted-pair cable. Both cables have different associated nominal amplitudes. For the 75Ω coaxial cable, the amplitude must be 2.37V ±10% at T0. For the 120Ω twisted-pair cable, the amplitude must be 3.0V ±10%. This pulse must fit within this template and cannot be scaled. **Table 2** shows E1 interface specifications for a pulse mask.

Table 2. E1 Interface Specification for Pulse Mask

Interface Parameters	Single Ended	Differential Pair
Nominal Line Rate	2.048Mbps	2.048Mbps
Medium	One coaxial pair is used for each direction of transmission.	One balanced twisted-pair cable is used for each direction of transmission.
Test-Load Impedance	A resistive test load of 75Ω ±5%.	A resistive test load of 120Ω ±5%.
Pulse Amplitude	The nominal pulse amplitude for a positive isolated pulse is 2.37V.	The nominal pulse amplitude for a positive isolated pulse is 3.0V.
Pulse Shape	Every pulse conforms to the mask in Figure 2.	Every pulse conforms to the mask in Figure 2.

T3 and E3 Pulse-Mask Template

When higher data rates are needed, T3 and E3 lines are often used. A T3 line (44.736Mbps) handles up to 28 T1 lines or 21 E1 lines; an E3 line (34.368Mbps) can hold up to 16 E1 lines. As with T1 and E1 networks, the T3 and E3 pulses must also meet a specified template. See **Figures 3** and **4** for a graphical representation of each template.

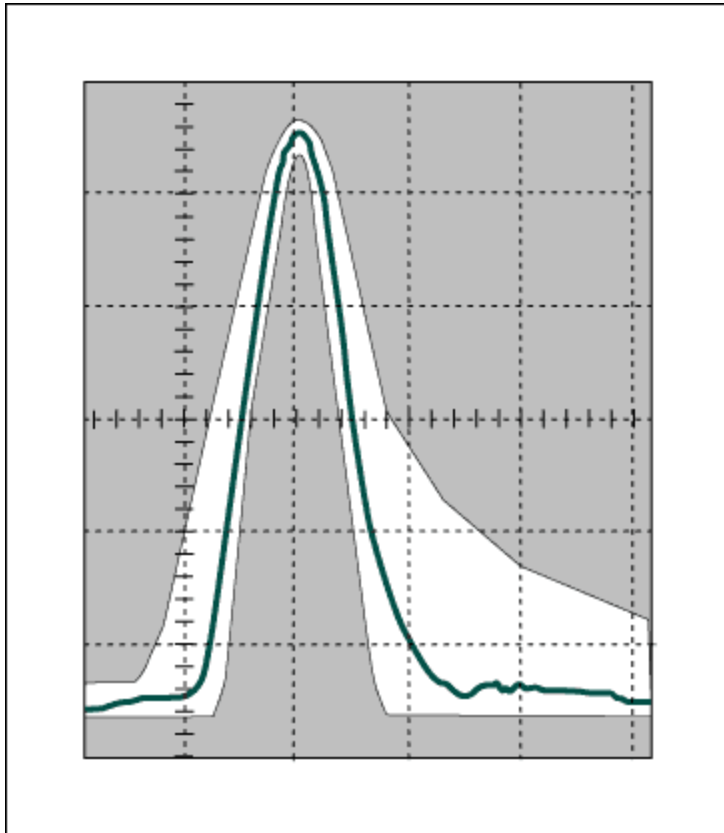

Figure 3. T3 pulses (44.736Mbps) must meet the template for the entire line length.

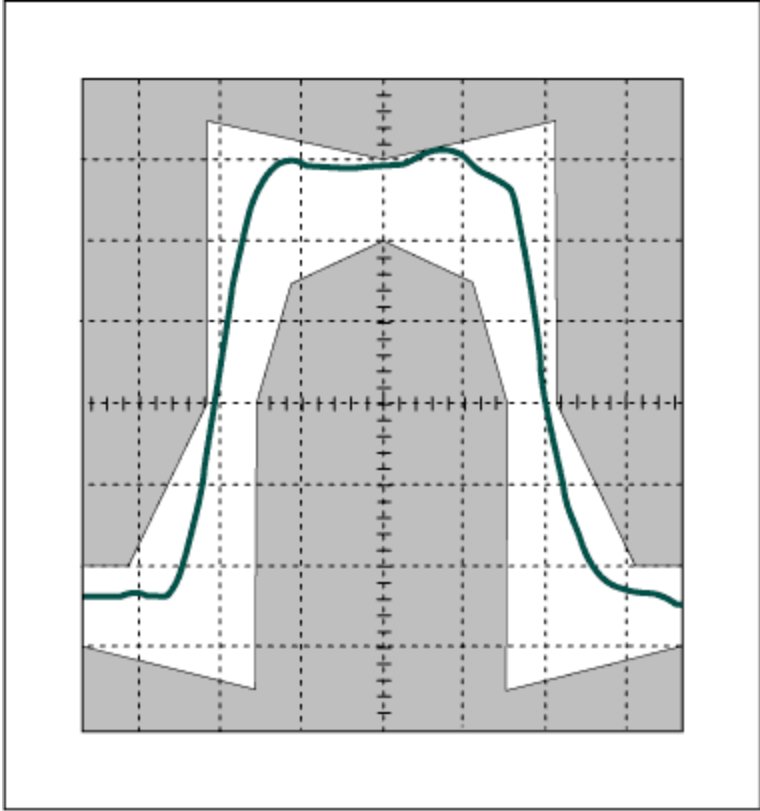

Figure 4. E3 pulse (34.368Mbps) signals are measured at the source.

Both the T3 and E3 pulses are terminated with 75Ω resistive loads. T3 pulses must meet the template for the entire line length, which can be up to 450ft. E3 signals are measured at the source. T3 and E3 interface specifications for pulse masks are shown in **Tables 3** and **4**, respectively.

Table 3. T3 Interface Specification for Pulse Mask

Interface Parameters	Specifications
Nominal Line Rate	44.736Mbps
Medium	One coaxial pair is used for direction of transmission.
Isolated Pulse	A positive pulse that is preceded by two zeros and followed by one or more zeros.
Test-Load Impedance	A resistive test load of 75Ω ±5%.
Pulse Amplitude	The pulse amplitude for a positive isolated pulse is between 0.36V and 0.85V.
Pulse Shape	The shape of every pulse that approximates an isolated pulse conforms to the mask in Figure 3. This shape is shown in a normalized form, with the nominal pulse amplitude shown as 1.0.

Table 4. E3 Interface Specification for Pulse Mask

Interface Parameters	Specifications
----------------------	----------------

Nominal Line Rate	34.368 Mbps
Medium	One coaxial pair is used for each direction of transmission.
Test-Load Impedance	A resistive test load of $75\Omega \pm 5\%$.
Pulse Amplitude	The nominal pulse amplitude for a positive isolated pulse is 1.0V.
Pulse Shape	The shape of every pulse that approximates an isolated pulse conforms to the mask in Figure 4.

Pulse-Mask Testing

Testing the pulse mask of a transmission device is a standard practice for not only the manufacturer, but also for the end users of telecommunications equipment. To perform this test, place the device in a mode where it is constantly transmitting a known data pattern. T1 and T3 networks have a spec to ensure that an isolated pulse is produced. For T1 signals, an isolated pulse is one preceded by four zeros and followed by one or more zeros. An isolated pulse for T3 signals is a pulse that is preceded by two zeros and followed by one or more zeros. To reduce the reflections during the measurement of the pulse mask, it is highly recommended to maximize the number of zeros before transmitting a one. E1 and E3 signals require that all pulses meet the specified template so there is not a spec for an isolated pulse.

The transmission line is then loaded with the appropriate resistor value and connected to an oscilloscope for measurement. **Figure 5** shows two common termination schemes. The upper drawing diagrams the proper way to terminate the differential transmission line. The scope must be set to receive a differential signal for this to function properly. T1 networks require a $100\Omega \pm 5\%$ resistive termination as the load; therefore, $50\Omega \pm 5\%$ resistors are used on TTIP and TRING. For E1, which is 120Ω termination, two $60\Omega \pm 5\%$ resistors are used.

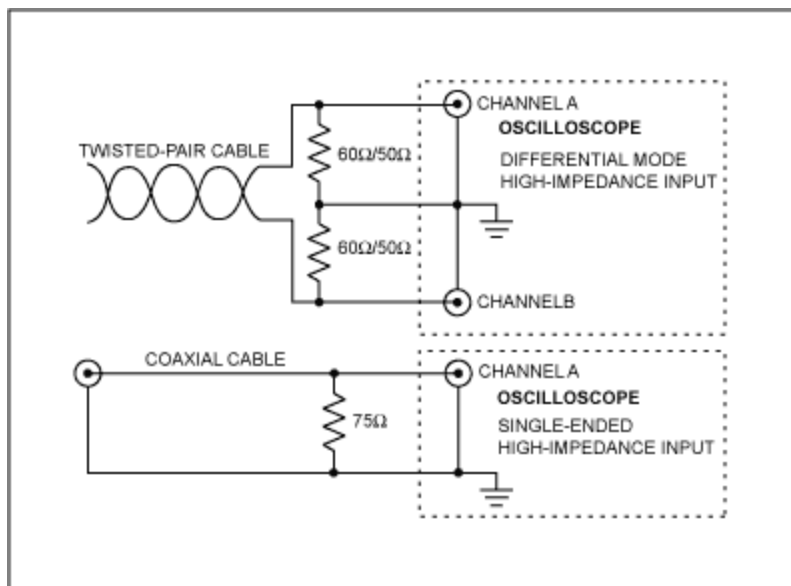

Figure 5. The upper drawing illustrates the proper way to terminate the differential transmission line, while the lower one is a termination example for single-ended transmission lines.

Viewing the pulse mask of a transmission signal while concurrently using the remaining channels of the oscilloscope for other purposes is often recommended. This requires use of an active differential probe, several are on the market. Use one that has the desired impedance termination and is rated for the

oscilloscope being used. Tektronix, LeCroy, and HP all make differential probes with termination that can be used with T1 or E1 transmission signals.

The lower termination scheme in Figure 5 is for single-ended transmission lines. To measure this pulse mask, simply add the termination resistor as close as possible to the high-impedance input of the oscilloscope. This will minimize the reflections and noise detected by the oscilloscope when making the pulse-mask measurement.

When different LBOs are required, as with T1 and T3 networks, a line simulator is usually added to provide proper capacitive loading on the transmission line (**Figure 6**).

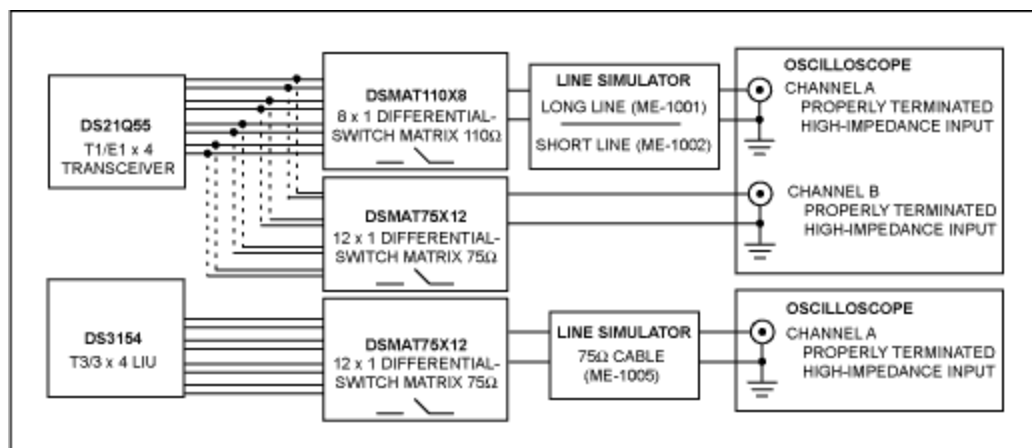

Figure 6. With T1 and T3 networks, a line simulator is usually added to provide the proper capacitive loading on the transmission line.

Problems with Testing Pulse Masks

A problem can develop with multiport transmission devices. While there are a number of multichannel oscilloscopes on the market that can measure multiple pulses at once, many of the line simulators are single-port only. An $N \times 1$ switch matrix is required to fully utilize both the line simulator and the oscilloscope without constantly moving cables for measurement. Maxim/Dallas Semiconductor developed two matrix cards that solve this problem and provide a GPIB interface for communicating to the board remotely. Both matrix boards are designed to be impedance controlled to reduce reflections in the measured signal. Also, each matrix board has a separate transmit and receive path for each signal path. This is useful when testing for receiver sensitivity.

Figure 6 represents a multiport T1/E1 single-chip transceiver (the DS21Q55) and a T3/E3 line-interface unit (the DS3154) with the associated hardware required for making a pulse-mask measurement.

In the upper block, notice the DSMAT110X8 between the DS21Q55 and the line simulator as well as the DSMAT75X12 between the DS21Q55 and the oscilloscope. The DSMAT110X8 is an 8×1 matrix card specifically designed for differential telecom signals that require 100Ω to 120Ω impedance matching. The DSMAT75X12 is a 12×1 matrix with 75Ω impedance matching and is designed for single-ended signals. The DS21Q55 can operate in both T1 and E1 modes with a variety of termination configurations: $75\Omega/100\Omega/120\Omega$. With so many configurations, checking if the device will meet pulse mask in all possible applications for every port quickly becomes difficult. The two matrix cards make this much easier by allowing the user to isolate signals on a certain port through a specified path. For example, in T1 mode a differential signal of 100Ω is required and the device must meet the template up to 655ft. By using the DSMAT110X8 card and the line simulator, the pulse mask can be measured for all possible LBOs. However, in E1 mode a differential signal of 120Ω or a single-ended signal of 75Ω

may be selected depending on the application. Therefore, the appropriate matrix must be used to prevent shorting one of the differential signals from the E1 twisted-pair cable. Pulse-mask testing for E1 is done at 0ft only so the line simulator is set for pass-through mode. It simply depends on how the device is configured.

The lower block in Figure 6 shows another multiport device, the DS3154. This device is similar to the DS21Q55 as it can switch between two different transmission modes, which in this case are T3 and E3. The specs for T3 and E3 call for 75Ω termination so only the DSMAT75X12 card is necessary. But again, for T3 mode the device must meet template for the entire LBO, so a line simulator is necessary. For E3 mode the line simulator is set in pass-through mode.

As the port counts increase on the data transmission equipment, so does the need for testing the transmission signal for pulse-mask compliance quickly and reliably. Maxim developed solutions to satisfy this need for both T1/E1 and T3/E3 applications.

Related Parts

DS21Q55	Quad T1/E1/J1 Transceiver	
DS3154	Single/Dual/Triple/Quad DS3/E3/STS-1 LIUs	Free Samples

More Information

For Technical Support: <http://www.maximintegrated.com/support>

For Samples: <http://www.maximintegrated.com/samples>

Other Questions and Comments: <http://www.maximintegrated.com/contact>

Application Note 1797: <http://www.maximintegrated.com/an1797>

APPLICATION NOTE 1797, AN1797, AN 1797, APP1797, Appnote1797, Appnote 1797

Copyright © by Maxim Integrated Products

Additional Legal Notices: <http://www.maximintegrated.com/legal>