

Keywords: 1-wire, master, slave, ibutton, parasitic supply, package, sfn, flip chip, ucsp, identification, control, temperature, time, nv sram, otp eeprom, eeprom, secure eeprom, logging, evaluation kit, ev kit, customization

TUTORIAL 1796

Overview of 1-Wire Technology and Its Use

By: Bernhard Linke, Principal Member Technical Staff

Jun 19, 2008

Abstract: This article provides a general overview of the 1-Wire® technology, its communication concept and, as a benefit of the low pin count, unusual package options. The main section discusses 1-Wire devices by their feature set and explains the typical applications. The article ends with practical information on how to evaluate 1-Wire devices, explains device customization options, and references resources that assist customers in integrating 1-Wire technology in their systems.

What Is 1-Wire Technology?

The basis of 1-Wire® technology is a **serial protocol** using a single data line plus ground reference for communication. A 1-Wire **master** initiates and controls the communication with one or more 1-Wire **slave** devices on the 1-Wire bus (**Figure 1**). Each 1-Wire slave device has a unique, unalterable, factory-programmed, **64-bit ID** (identification number), which serves as device address on the 1-Wire bus. The 8-bit **family code**, a subset of the 64-bit ID, identifies the device type and functionality. Typically, 1-Wire slave devices operate over the voltage range of 2.8V (min) to 5.25V (max). Most 1-Wire devices have no pin for power supply; they take their energy from the 1-Wire bus (**parasitic supply**).

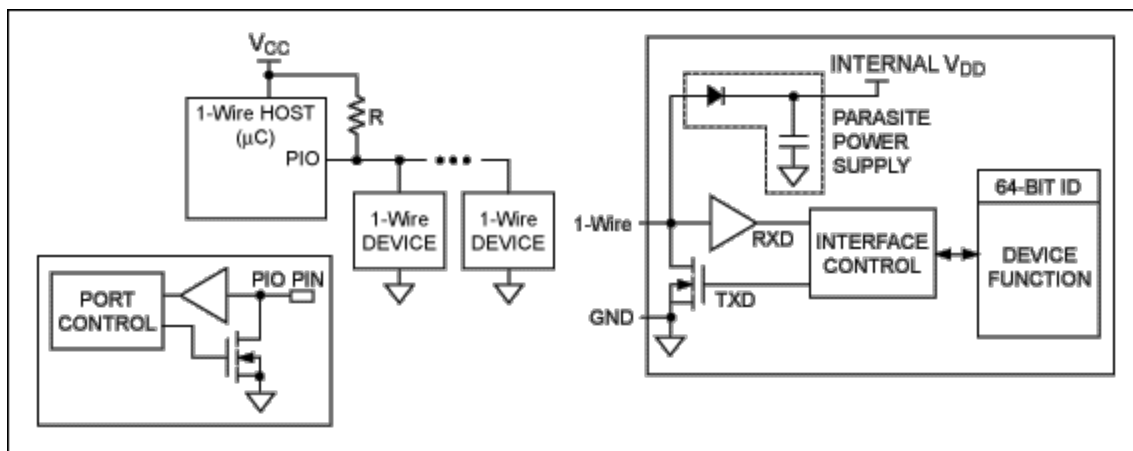

Figure 1. The 1-Wire master/slave configuration uses a single data line plus ground reference.

What Is Special About 1-Wire?

1-Wire is the only voltage-based digital system that works with two contacts, data and ground, for half-duplex bidirectional communication. In contrast to other serial communication systems such as I²C or SPI, 1-Wire devices are designed for use in a contact environment. Either disconnecting from the 1-Wire bus or a loss of contact puts the 1-Wire slaves into a defined reset state. When the voltage returns, the slaves wake up and signal their presence. With only one contact to protect, the built-in ESD protection of 1-Wire devices is extremely high. With two contacts, 1-Wire devices are the most economical way to add electronic functionality to nonelectronic objects for identification, authentication, and delivery of calibration data or manufacturing information.

How Are 1-Wire Devices Packaged?

1-Wire devices are offered in conventional transistor (TO-92) and IC packages (TSOC, SOIC, SOT23). Designed for contact applications and easy attachment, the 2-contact SFN¹ package accommodates parasitically powered 1-Wire devices (**Figure 2**). The 16mm-diameter stainless steel iButton^{®2} package protects 1-Wire devices from harsh environments, making them suitable for indoor and out door use (**Figure 3**). Many devices are also available in flip chip (**Figure 4**) and UCSP^{™3} (**Figure 5**) versions.

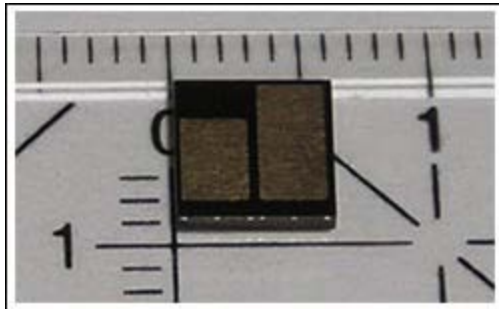

Figure 2. The 6.0mm x 6.0mm x 0.9mm SFN package has large contact areas.



Figure 3. The 16mm-diameter iButton package protects the 1-Wire chip inside from harsh environments.

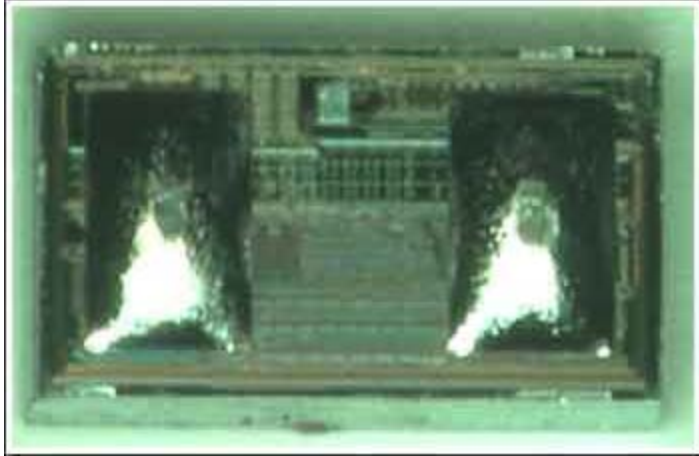

Figure 4. The flip chip DS2502 package, 1.6mm x 0.91mm, has two rectangular contacts.

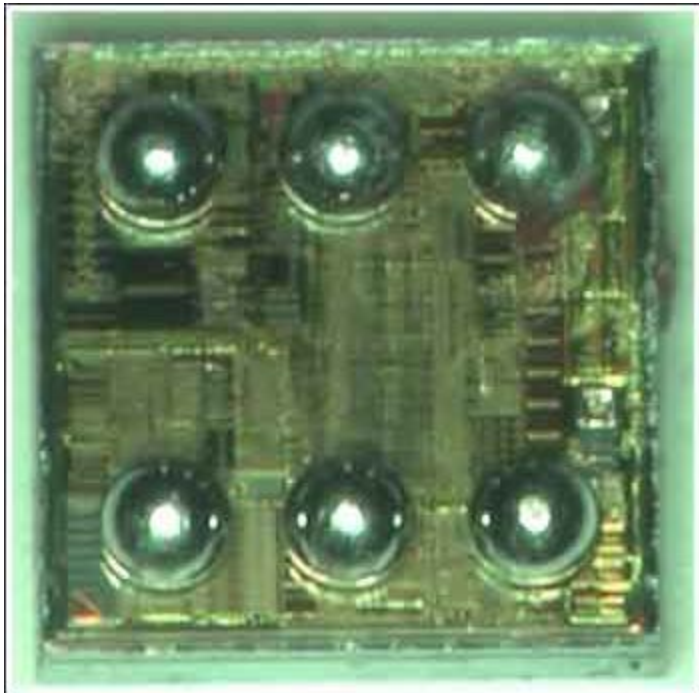

Figure 5. The UCSP package, 1.68mm x 1.68mm, for the DS2431 has spherical contacts located on a grid with a 0.5mm pitch.

What Device Functions Are Available, and What Are the Typical Applications?

At this time, there are approximately 40 1-Wire devices, including some close to the end of their lifetime. The part numbers listed here only include devices scheduled for normal production for the foreseeable future. Part numbers that begin with DS19 are always iButtons. The remaining part numbers in this section, i.e., those that begin with DS24, DS25, and DS28 are available in conventional plastic packages. If a product is also available as SFN or flip chip/UCSP, then this is mentioned in the Notes column. To find up-to-date package information for any device, go to the [Maxim website](#) and enter the part number

in the part number search field.

1-Wire devices can be grouped by their functions into several categories:

- Identification only
- Identification plus control
- Identification plus temperature
- Identification plus time
- Identification plus NV SRAM
- Identification plus (one time programmable) OTP EPROM
- Identification plus EEPROM
- Identification plus SHA-1 secure EEPROM
- Identification plus logging

The combination of additional resources determines the typical application areas for a device. There are numerous other applications that, for practical reasons, cannot be listed here.

Identification Only

Devices in this category are notable for their low cost. Accordingly, the level of protection that they can provide is limited. If the DS2401 or DS2411 is used for the protection of intellectual property (IP), one should consider a customized version of the device. See section **Is There Any Device Customization?** for more details.

Part Number	Notes	Typical Applications
DS2401	The DS2401 is also available as flip chip. Since the DS2401 does not need a V_{CC} supply, this part is also suitable for identification of printer cartridges and medical consumables.	<ul style="list-style-type: none"> • Printed circuit board (PCB) identification and authentication • Accessory/peripheral identification • Protection of IP • Consumer electronics
DS2411	V_{CC} power, 1.5V or higher	
DS1990A DS1990R	The DS1990R is guaranteed to generate a presence pulse on contact to reader.	<ul style="list-style-type: none"> • Printer cartridge identification • Access control • Asset management

Identification plus Control

The applications for these parts are similar to the devices above. The PIOs, however, add control or feedback capability to the system.

Part Number	Notes	Typical Applications
DS2413	Two 28V PIOs	<ul style="list-style-type: none"> • Identification of printer cartridges and medical consumables • Rack card control • Accessory/peripheral identification and control
DS2450	Four 5V ADC inputs, which can also function as digital PIO. This device can be V_{CC} powered.	<ul style="list-style-type: none"> • Consumer electronics

Identification plus Temperature

In large electronic equipment (racks) the proper cooling/air flow is critical for reliable operation. The DS28EA00 solves this problem in a unique way through its chain function,⁴ which allows detecting the physical sequence of the device on the 1-Wire bus. When wired for sequence detection, one of the two PIOs is available for control functions.

Part Number	Notes	Typical Applications
DS28EA00	If not wired for sequence detection, two PIOs are available for control functions.	<ul style="list-style-type: none"> • Rack card monitoring
DS1920	This stand-alone device measures temperature on command, e.g., when a reader touches it.	<ul style="list-style-type: none"> • Temperature data collection on contact

Identification plus Time

These devices measure time by counting seconds using a 32-bit binary counter.⁵ Knowing the 0-time reference point (i.e., January 1, 1970, 00:00:00 hours UTC), one can identify any second within 136 years. Counting seconds is particularly convenient to measure time intervals.

Part Number	Notes	Typical Applications
DS2417	The DS2417 is also available as flip chip. Periodic timer interrupt, requires 6pF 32KHz crystal.	<ul style="list-style-type: none"> • Consumer electronics
DS1904L	This stand-alone iButton includes battery and crystal. This device is also suited for guardtour, and time and attendance applications.	

Identification plus NV SRAM

Of the devices in this category, the DS1963S is quite unique. Besides its memory, it includes a SHA-1 engine, eight 64-bit secrets, sixteen 32-bit write cycle counters, and one 32-bit pseudo-random number generator. Although the 4Kb memory can be read and written without restrictions, changing the data in pages 8 to 15 or in any one of the secrets causes the associated write cycle counter to increment. By design, the DS1963S can function as a secure token for electronic cash applications, and as a SHA-1 coprocessor⁶ for use with SHA-1 secure EEPROMs. The security is achieved by embedding a SHA-1 MAC (message authentication code) in a data page. When used for PCB authentication or protection of IP, the DS1963S functions as a coprocessor to aid the host in validating SHA-1 secure EEPROMs or data with an embedded MAC read from simple memory devices (e.g., NV SRAM, EPROM, EEPROM).

Part Number	Notes	Typical Applications
DS1963S	4Kb memory, SHA-1 engine with 8 secrets, 16 write cycle counters, pseudo-random number generator	<ul style="list-style-type: none"> • PCB authentication • Protection of IP • Electronic cash
DS1992L	1Kb memory	<ul style="list-style-type: none"> • PCB identification and authentication • Access control • Asset management
DS1993L	4Kb memory. Due to its lower cost (compared to the DS1995/DS1996), this device is also suited for printed circuit board identification and authentication.	<ul style="list-style-type: none"> • Protection of IP • Access control • Asset management
DS1995L	16Kb memory	
DS1996L	64Kb memory	

Identification plus OTP EPROM

All devices in this category use 12V EPROM technology. Since the packages do not have openings, the bits are OTP; once changed from 1 to 0, they cannot be reversed. To mark an entire 32-byte page as invalid and to point to an alternate location for valid data, these devices have redirection bytes, one for each page. This unique feature allows changing data while maintaining the change history. Individual memory pages can be irreversibly write-protected. Write protection makes OPT EPROMs prime candidates for applications that need a small amount of data that rarely changes, such as network addresses⁷ and printed circuit board identification.⁸

Part Number	Notes	Typical Applications
DS2502	1Kb memory. The DS2502 is also available in flip chip and SFN versions.	<ul style="list-style-type: none"> • Identification and usage monitoring of printer cartridges and medical consumables • Identification and authentication of rack cards and printed circuit boards • Accessory/peripheral identification
DS2505	16Kb memory	
DS2502-E48	1Kb memory, preprogrammed with a MAC-48/EUI-48 Ethernet address	<ul style="list-style-type: none"> • Network address • PCB identification and authentication
DS2502-E64	1Kb memory, preprogrammed with an IEEE® EUI-64 node address	
DS1982	1Kb memory. Due to its lower cost (compared to the DS1985), the DS1982 is also suited for printer cartridge identification and usage monitoring.	<ul style="list-style-type: none"> • PCB identification and authentication • Asset management
DS1985	16Kb memory	

Identification plus EEPROM

Compared to the OTP EPROMs above, devices in this category do not need 12V for writing. Data can be changed (rewritten), provided that the memory area or page is not write-protected. Most of these devices have an EPROM emulation mode, which allows changing bits only from 1 to 0, as with EPROMs. Due to its high capacity and security, the DS1977 is used in the gaming industry.

Part Number	Notes	Typical Applications
DS2431	1Kb memory, EPROM emulation, page write protection. The DS2431 is also available in UCSP and SFN versions.	<ul style="list-style-type: none"> • Identification and usage monitoring of printer cartridges and medical consumables • Identification and authentication of rack cards and PCBs • Accessory/peripheral identification • Protection of IP and authentication • Consumer electronics
DS28EC20	20Kb memory, EPROM emulation, block (four pages) write protection	
DS2433	4Kb memory. The DS2433 is also available in flip chip and SFN versions.	<ul style="list-style-type: none"> • Identification and usage monitoring of printer cartridges and medical consumables • Identification and authentication of rack cards and PCBs • Accessory/peripheral identification
DS28E04	4Kb memory, two 5V PIOs, 7 1-Wire address inputs, EPROM emulation, page write-protection	<ul style="list-style-type: none"> • Rack Card identification and authentication
DS1971	256b memory	<ul style="list-style-type: none"> • Access control
DS1972	1Kb memory, EPROM emulation, page write protection	<ul style="list-style-type: none"> • Access control • Asset management
DS1973	4Kb memory	
DS1977	32KB memory, password protection	<ul style="list-style-type: none"> • Asset management • Gaming

Identification plus SHA-1 Secure EEPROM

Writing to the devices in this secure category requires knowledge of the device's secret and the ability to compute a SHA-1 MAC. Except for the secret, memory data is readable without restrictions. All three devices support challenge and response authentication, EPROM emulation for one memory page, and write protection of the secret and memory pages. The challenge and response authentication provides a very high level of security to prevent cloned components from being accepted in a system.⁹ Designed for a contact environment, the DS1961S also supports a refresh function that allows the rewriting of existing

data without providing a SHA-1 MAC. See section **Is There Any Device Customization?** for preprogramming service.

Part Number	Notes	Typical Applications
DS2432	1Kb memory, one 64-bit secret, 3-byte challenge. The DS2432 is also available in a flip chip version.	<ul style="list-style-type: none"> • Identification and usage monitoring of printer cartridges and medical consumables.
DS28E01	1Kb memory, one 64-bit secret, 5-byte challenge	<ul style="list-style-type: none"> • Identification and usage monitoring of printer cartridges and medical consumables • Identification and authentication of rack cards and PCBs • Accessory/peripheral identification • Protection of IP and authentication • Consumer electronics
DS1961S	1Kb memory, one 64-bit secret, 3-byte challenge, refresh function	<ul style="list-style-type: none"> • PCB identification and authentication • Protection of IP and authentication • Electronic cash

Identification plus Logging

These devices are self-contained data loggers for temperature data. The DS1923 can also record humidity. The principal differences among the devices are the size of the data memory and the level of data protection (password). Devices for different temperature ranges are available to meet the requirements of the various applications.¹⁰

Part Number	Notes	Typical Applications
DS1921G	2KB temperature logger, -40°C to +85°C	<ul style="list-style-type: none"> • Temperature monitoring for environmental science • Temperature monitoring for food safety • Quality assurance for shipments of food, produce, and pharmaceutical products
DS1921H	2KB temperature logger, high resolution, +15°C to +46°C	
DS1921Z	2KB temperature logger, high resolution, -5°C to +26°C	
DS1922L	8KB temperature logger, -40°C to +85°C, password protection	
DS1922T	8KB temperature logger, 0°C to +125°C, password protection	
DS1923	8KB temperature and humidity logger, -20°C to +85°C, password protection	

How Does One Get Hands-On Experience with 1-Wire Products?

If an IBM®-compatible PC with USB or RS-232 serial port and Internet access is available, the only missing pieces are: a 1-Wire adapter, evaluation (EV) software, some simple cabling, and the 1-Wire devices to evaluate. The current product prices and availability can be found on the Maxim website. The OneWireViewer software¹¹ and related drivers can be downloaded for free.

A more economical approach is to buy one of the EV kits. Each kit includes a 1-Wire adapter, a selection of 1-Wire devices or iButtons, and the necessary cabling and accessories. **Table 1** describes the EV kits at the time of this publication. The contents of EV kits can change as new parts become available. Devices not included in a kit need to be purchased separately. Since the EV kit's software is the same (except for the DSECASH kit), the package type (plastic package or iButton) determines which kit best fits an application.

Table 1. EV Kit Overview

Kit Part Number	Evaluates	1-Wire Adapter Type	Notes
DS9090K#	1-Wire chips (plastic packages)	USB, DS9490R	Includes: EV board with sockets for TO-92, TSOC, RJ-11 cable; jumpers; DS2401, DS2413, DS2431, DS2432, DS2433, DS28E04, and DS28EC20; other 1-Wire parts not mentioned in this document
DS9092K#	iButtons	USB, DS9490R	Includes: cable with iButton probe; DS1990A, DS1971, DS1904L, and DS1996; mechanical iButton mounting accessories
DS1921K#	iButton Data Loggers	USB, DS9490R	Includes: cable with iButton probe; DS1921G; mechanical mounting accessories
DS28EA00EVKIT#	DS28EA00	USB, DS9490R	Includes: three EV boards with DS28EA00 installed and RJ-11 cables
DSECASH	DS1963S, DS1961S iButtons for eCash	RS-232, DS9097U-S09	Includes: EV board; cable with iButton probe; RJ-11 cable; several DS1963S and DS1961S iButtons; mechanical iButton mounting accessories

What Are the Next Steps to a 1-Wire Application?

Once the 1-Wire products are selected, one needs to choose a type of master circuit (i.e., the equivalent of the 1-Wire adapter in the kits). For embedded applications, there is a multitude of choices, based on the available system resources.¹² Applications that require significant cabling between the 1-Wire devices benefit from a specialized master circuit.¹³

Besides hardware, firmware is needed to communicate with the 1-Wire devices, to write or read data, and to exercise control functions. A selection of software drivers¹⁴ for various platforms is available for free download from the Maxim website. For device-specific drivers, application program interfaces (APIs), and software examples, refer to the *1-Wire Software Resource Guide*.¹⁵ This guide also includes API functions based on the 1-Wire File system,¹⁶ which are particularly useful when working with more than a few hundred bytes of data.

Is There Any Device Customization?

Maxim offers two types of device customization. Custom ROM is quite popular with identification-only devices, but is applicable to all devices with a 64-bit ID number. With custom ROM, a pool of 68.7×10^9 numbers (equivalent to 36 bits) is committed to the sole use of a single customer. Examples of Custom ROM are found in application note 178.⁸ This type of customization occurs before packaging, which

leads to a fairly long lead-time. For SHA-1 secure EEPROM devices, Maxim provides a secure preprogramming service to install data and secret. For details, submit a [tech support request](#) to the factory.

Summary

1-Wire technology is based on a serial communication protocol that uses a single data line plus ground reference between master and slave. The 1-Wire slaves are available in plastic packages, as flip chip or UCSP, or in the form of stainless-steel iButtons. The minimum function of 1-Wire slaves is a 64-bit ID number. Additional functions are PIO, temperature sensor, time counter, NV SRAM, OTP EPROM, EEPROM, SHA-1 engine, SHA-1 secure EEPROM, temperature logging and humidity logging. Typical applications for 1-Wire devices include identification and authentication of consumables, rack cards, PCBs, computer accessories, and the protection of IP (e.g., cloning prevention). Special uses of iButtons are access control, asset management, guardtour systems, time and attendance, electronic cash (eCash), and temperature monitoring for food and pharmaceutical safety. Starter EV kits and software drivers are available to assist customers integrating 1-Wire technology in their systems.

References

1. Application note 4132, "[Attachment Methods for the Electro-Mechanical SFN Package](#)"
2. Application note 3808, "[What Is an iButton?](#)"
3. Application note 4002, "[Understanding Flip-Chip and Chip-Scale Package Technologies and Their Applications](#)"
4. Application note 4037, "[Regain Location Information by Leveraging the 1-Wire Chain Function—A Simple Signaling and Protocol Method Determines Device Physical Location](#)"
5. Application note 517, "[DS1371/DS1372/DS1374 32-Bit Binary Counter Time Conversion](#)"
6. Application note 1820, "[White Paper 1: SHA Devices Used in Small Cash Systems](#)"
7. Application note 186, "[Creating Global Identifiers Using 1-Wire Devices](#)"
8. Application note 178, "[Printed Circuit Board Identification Using 1-Wire Products](#)"
9. Application note 3675, "[Protecting the R&D Investment—Two-Way Authentication and Secure Software Feature Settings](#)"
10. Application note 3892, "[Overview of iButton Sensors and Temperature/Humidity Dataloggers](#)"
11. Application note 3358, "[OneWireViewer User's Guide](#)"
12. Application note 4206, "[Choosing the Right 1-Wire® Master for Embedded Applications](#)"
13. Application note 244, "[Advanced 1-Wire Network Driver](#)"
14. Start page, [Software Development Kits](#)
15. Application note 155, "[1-Wire Software Resource Guide Device Description](#)"
16. Application note 114, "[1-Wire File Structure](#)"

1-Wire is a registered trademark of Maxim Integrated Products, Inc.

IBM is a registered trademark and registered service mark of International Business Machines Corporation.

iButton is a registered trademark of Maxim Integrated Products, Inc.

IEEE is a registered service mark of the Institute of Electrical and Electronics Engineers, Inc.

UCSP is a trademark of Maxim Integrated Products, Inc.

Related Parts

DS1921K	Thermochron iButton Starter Kit
DS28EA00EVKIT	Evaluation Kit for the DS28EA00
DS9090K	1-Wire Device Evaluation Kit Rev B4
DS9092K	iButton Starter Kit

More Information

For Technical Support: <http://www.maximintegrated.com/support>

For Samples: <http://www.maximintegrated.com/samples>

Other Questions and Comments: <http://www.maximintegrated.com/contact>

Application Note 1796: <http://www.maximintegrated.com/an1796>

TUTORIAL 1796, AN1796, AN 1796, APP1796, Appnote1796, Appnote 1796

© 2013 Maxim Integrated Products, Inc.

Additional Legal Notices: <http://www.maximintegrated.com/legal>